

Spare Parts Catalogue

Version: 2011/02/20a EN



DOLOMITE[®] ADVANCED



DOLOMITE[®] ADVANCED
PLATFORM



Yes, you can.®

General Information

For any order of spare parts the following information is required:

- Product type*
- Product name & model*
- Serial Number*
- Part-Number*
- Part-Description*

Exploded view drawings and code numbers are not contractual and subject to modification, in relation to Invacare® continuous product improvement policy to meet end users needs.

The reproduction or use of this work, or of any substantial part of this work, in any form or by any electronic, mechanical or other means, including photocopying, scanning and recording, and in any information storage and retrieval system, including electronic transmission, is forbidden without the prior written permission of Invacare® International Sarl.



Yes, you can.[®]

TABLE OF CONTENTS

Spare parts	5
Accessories	6

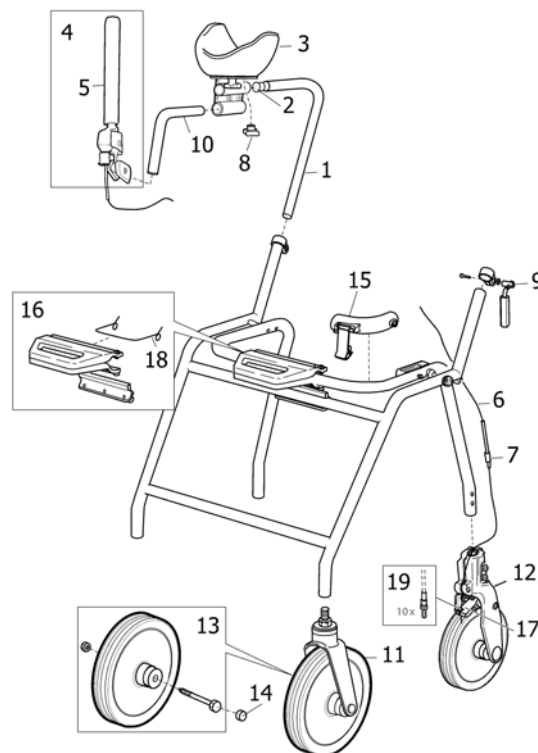

SPS151029

Pos.	Part number	Description	Valid from → until	Qty
	82035	User manual		1
1	13627	Height adjustment tube		1
2	1452465	End Cap, 10-pack <i>Replaces 70334</i>		1
3	13005-L	Forearm support left		0
3	13005-R	Forearm support right		0
4	1510549	Brake handle complete <i>Replaces 13055</i>		1
5	12677	Soft handgrip L=220 mm, 2 units		1
6	1452466	Wire L=1330 mm 10-pack		1
7	80075	Wire cover L=1000 mm		1
8	1452467	Knob 10-pack <i>Replaces 60042</i>		1
9	1452468	Locking device with clamp, 2 units		1
10	13628	Handle tube	2003-01-01 →	1
11	13565-25-V01	Front fork complete with SL II wheel grey		0
12	12590-25	Rear fork complete with SL II wheel grey		0
13	12609	SL II wheel complete with locking nut		0
14	1452282	Cover 20 pcs		0
15	1452288	Folding lock red 10 pcs		0
15	12656	Folding lock complete		0
16	1510376	Folding mechanism kit <i>Replaces 12622 and 12647</i>		0
17	12620	Brake shoe complete		0
18	1529858	Spring for Foldinghandle 10 pcs <i>Replaces 72025</i>		0
19	1542524	Adjustmentscrew with nut, 10 pcs		1

Accessories

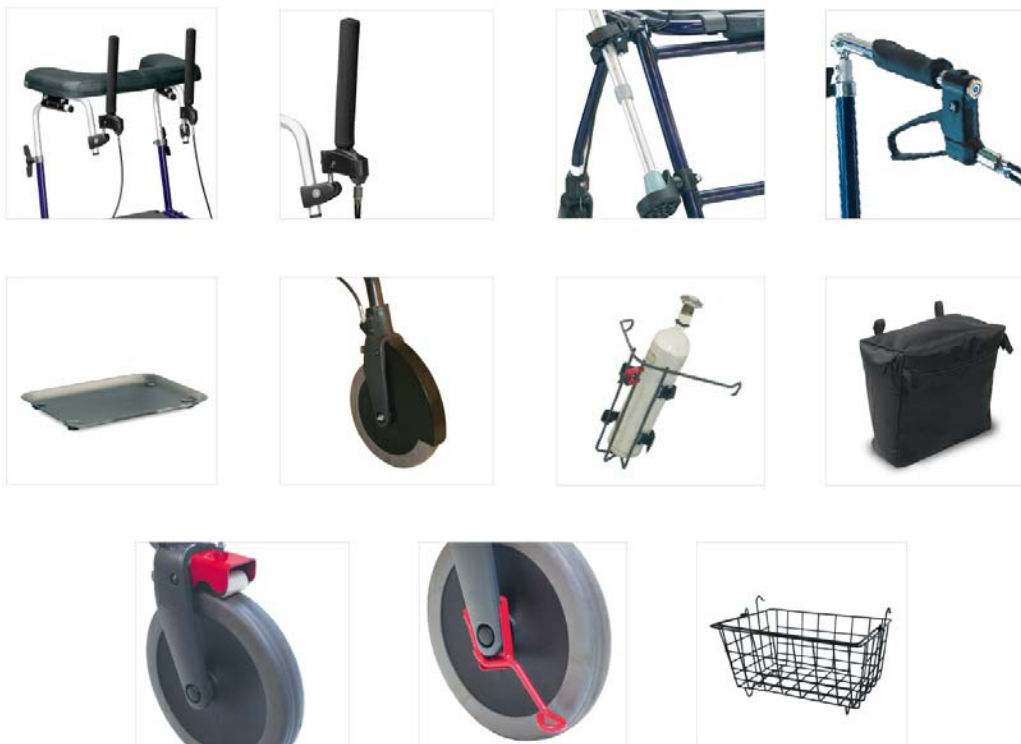

Pos.	Part number	Description	Valid from → until	Qty
1	13018	Platform support		1
2	12515	One-hand brake		1
3	12606	Cane holder		1
4	12612-L	Adapt handles with one-hand brake left		1
4	12612-R	Adapt handles with one-hand brake right		1
5	70311	Tray		1
6	12544	Wheel guard, pair		1
7	12682-25	Oxygen holder		1
8	12523	Bag black		1
9	13041-21	Slow-down-brake, 2 units		1
10	12560-21	Kerb climber right side		1
11	12530-15	Basket, max load 9 kg		1



Yes, you can.®



Belgium & Luxemburg:

Invacare nv, Autobaan 22, B-8210 Loppem
Tel: (32) (0)50 83 10 10, Fax: (32) (0)50 83 10 11
belgium@invacare.com / www.invacare.be

Denmark:

Invacare A/S, Sdr. Ringvej 37, DK-2605 Brøndby
Tel: (45) (0)36 90 00 00, Fax: (45) (0)36 90 00 01
denmark@invacare.com / www.invacare.dk

Deutschland:

Invacare Aquatec GmbH, Alemannenstraße 10, D-88316 Isny
Tel: (49) (0)75 62 7 00 0, Fax: (49) (0)75 62 7 00 66
info@invacare-aquatec.com / www.invacare-aquatec.de

European Distributor Organisation:

Invacare, Kleiststraße 49, D-32457 Porta Westfalica
Tel: (49) (0)57 31 754 540, Fax: (49) (0)57 31 754 541
edo@invacare.com / www.invacare.eu.com

España:

Invacare SA, c/Areny s/n, Polígon Industrial de Celrà, E-17460 Celrà (Girona)
Tel: (34) (0)972 49 32 00, Fax: (34) (0)972 49 32 20
contactsp@invacare.com / www.invacare.es

France:

Invacare Poirier SAS, Route de St Roch, F-37230 Fondettes
Tel: (33) (0)2 47 62 64 66, Fax: (33) (0)2 47 42 12 24
contactfr@invacare.com / www.invacare.fr

Ireland:

Invacare Ireland Ltd, Unit 5 Seatown Business Campus, Seatown Road, Swords, County Dublin - Ireland
Tel: (353) 1 810 7084, Fax: (353) 1 810 7085
ireland@invacare.com / www.invacare.ie

Italia:

Invacare Mecc San s.r.l., Via dei Pini 62, I-36016 Thiene (VI)
Tel: (39) 0445 38 00 59, Fax: (39) 0445 38 00 34
italia@invacare.com / www.invacare.it

Nederland:

Invacare BV, Celsiusstraat 46, NL-6716 BZ Ede
Tel: (31) (0)318 695 757, Fax: (31) (0)318 695 758
nederland@invacare.com, csede@invacare.com / www.invacare.nl

Norge:

Invacare AS, Grensesvingen 9, Postboks 6230, Etterstad, N-0603 Oslo
Tel: (47) (0)22 57 95 00, Fax: (47) (0)22 57 95 01
norway@invacare.com, island@invacare.com / www.invacare.no

Österreich:

Invacare Austria GmbH, Herzog Odilostrasse 101, A-5310 Mondsee
Tel: (43) 6232 5535 0, Fax: (43) 6232 5535 4
info-austria@invacare.com / www.invacare.at

Portugal:

Invacare Lda, Rua Estrada Velha, 949, P-4465-784 Leça do Balio
Tel: (351) (0)225 1059 46/47, Fax: (351) (0)225 1057 39
portugal@invacare.com / www.invacare.pt

Sverige & Suomi:

Invacare AB, Fagerstagatan 9, S-163 91 Spånga
Tel: (46) (0)8 761 70 90, Fax: (46) (0)8 761 81 08
sweden@invacare.com, finland@invacare.com / www.invacare.se

Switzerland:

Invacare AG, Benkenstrasse 260, CH-4108 Witterswil
Tel: (41) (0)61 487 70 80, Fax: (41) (0)61 487 70 81
switzerland@invacare.com / www.invacare.ch

United Kingdom:

Invacare Limited, Pencoed Technology Park, Pencoed, Bridgend CF35 5AQ
Switchboard Tel: (44) (0)1656 776200, Fax: (44) (0)1656 776201
Customer services Tel: (44) (0)1656 776222, Fax: (44) (0)1656 776220
uk@invacare.com / www.invacare.co.uk