

Küschall® Compact

Compact SA / Compact FF

en **Active wheelchair
User Manual**



This manual **MUST** be given to the user of the product.
BEFORE using this product, this manual **MUST** be read and saved for
future reference.

Küschall®
UNLIMIT YOUR WORLD

© 2019 Invacare Corporation

All rights reserved. Reproduction, duplication or modification in whole or in part is prohibited without prior written permission from Invacare. Trademarks are identified by ™ and ®. All trademarks are owned by or licensed to Invacare Corporation or its subsidiaries unless otherwise noted.

Contents

1 General	5
1.1 Introduction	5
1.2 Symbols in this Document	5
1.3 Warranty Information	5
1.4 Compliance	6
1.4.1 Product-specific standards	6
1.5 Service Life	6
1.6 Limitation of Liability	6
2 Safety	7
2.1 Safety information	7
2.2 Labels and Symbols on the Product	8
3 Product Overview	11
3.1 Intended Use	11
3.2 Product description	11
3.3 Main parts of the wheelchair	12
3.4 Parking Brakes	12
3.5 Backrest	14
3.5.1 Push handles	15
3.6 Folding backrest (optional)	16
3.7 Stabilizing bar for the backrest	16
3.8 Side parts	17
3.8.1 Tubular armrest, non-locking, height-adjustable, removable, swivelling	17
3.8.2 Side rest, stepless height-adjustable, non-locking	17
3.8.3 Kuschall Armrest	18
3.8.4 Mudguard	19
3.8.5 Clothes-guard	20
3.9 Leg rests	20
3.10 Seat cushion	21
4 Options	22
4.1 Antitipper	22
4.2 Posture belt	23
4.3 Transit wheels	25
4.4 Tipper aid	26
4.5 Swing away, angle adjustable leg rests	26
4.6 Amputee Support	28
4.7 One arm drive	29
4.8 Cane holder	30
4.9 Luggage carrier	31
4.10 Calf Strap / Heel Loop	31
4.11 Air pump	31
4.12 Passive illumination	31
5 Setup	32
5.1 Safety information	32
6 Usage	33
6.1 Safety information	33
6.2 Braking during Use	33
6.3 Getting in and out of the wheelchair	34
6.4 Driving and Steering the Wheelchair	35
6.5 Negotiating steps and kerbs	36
6.6 Going up and down stairs	38
6.7 Negotiating ramps and slopes	38
6.8 Stability and balance when seated	40
6.9 Transporting the occupied wheelchair in a vehicle	41
7 Transport	46
7.1 Safety information	46
7.2 Folding and unfolding the wheelchair	46
7.3 Removing and Installing the Rear Wheels	47
8 Maintenance	48
8.1 Safety information	48
8.2 Maintenance Schedule	48
8.3 Cleaning and Disinfection	50
8.3.1 General Safety Information	50
8.3.2 Cleaning Intervals	51
8.3.3 Cleaning	51
8.3.4 Disinfection	51

9 After Use	52
9.1 Storage	52
9.2 Reconditioning	52
9.3 Disposal	52
10 Troubleshooting	53
10.1 Safety information	53
10.2 Identifying and repairing Faults	54
11 Technical Data	56
11.1 Dimensions and Weight	56
11.2 Tyres	57
11.3 Materials	58
11.4 Environmental conditions	58

1 General

1.1 Introduction

This user manual contains important information about the handling of the product. To ensure safety when using the product, read the user manual carefully and follow the safety instructions.

Note that there may be sections in this document, which are not relevant to your product, since this document applies to all available models (on the date of printing). If not otherwise stated, each section in this document refers to all models of the product.

The models and configurations available in your country can be found in the country-specific sales documents.

Invacare reserves the right to alter product specifications without further notice.

Before reading this document, make sure you have the latest version. You find the latest version as a PDF on the Invacare website.

If you find that the font size in the printed document is difficult to read, you can download the PDF version from the website. The PDF can then be scaled on screen to a font size that is more comfortable for you.

For more information about the product, for example product safety notices and product recalls, contact your Invacare distributor. See addresses at the end of this document.

In case of a serious incident with the product, you should inform the manufacturer and the competent authority in your country.

1.2 Symbols in this Document

Symbols and signal words are used in this document and apply to hazards or unsafe practices which could result in personal injury or property damage. See the information below for definitions of the signal words.



WARNING

Indicates a hazardous situation that could result in serious injury or death if it is not avoided.



CAUTION

Indicates a hazardous situation that could result in minor or slight injury if it is not avoided.



IMPORTANT

Indicates a hazardous situation that could result in damage to property if it is not avoided.



Tips and Recommendations

Gives useful tips, recommendations and information for efficient, trouble-free use.

1.3 Warranty Information

We provide a manufacturer's warranty for the product in accordance with our General Terms and Conditions of Business in the respective countries.

Warranty claims can only be made through the provider from whom the product was obtained.

1.4 Compliance

Quality is fundamental to the company's operation, working within the disciplines of ISO 13485.

This product features the CE mark, in compliance with the Medical Device Regulation 2017/745 Class I. The launch date of this product is stated in the CE declaration of conformity.

We are continuously working towards ensuring that the company's impact on the environment, locally and globally, is reduced to a minimum.

We only use REACH compliant materials and components.

1.4.1 Product-specific standards

The wheelchair has been tested in accordance with EN 12183. It includes testing for flammability.

For further information about local standards and regulations, contact your local Invacare representative. See addresses at the end of this document.

1.5 Service Life

The expected service life of this product is five years when used daily and in accordance with the safety instructions, maintenance intervals and correct use, stated in this manual. The effective service life can vary according to frequency and intensity of use.

1.6 Limitation of Liability

Invacare accepts no liability for damage arising from:

- Incorrect use
- Natural wear and tear
- Incorrect assembly or set-up by the purchaser or a third party
- Technical modifications
- Unauthorised modifications and/or use of unsuitable spare parts

- Non-compliance with the user manual

2 Safety

2.1 Safety information

This section contains important safety information for the protection of the wheelchair user and assistant and for safe, trouble-free use of the wheelchair.



WARNING!

Risk of accidents and serious injury

Accidents with resulting serious injury can occur if the wheelchair is improperly adjusted.

- Wheelchair adjustments must always be carried out by a qualified technician.



WARNING!

Risk due to driving style being unsuitable for the conditions

There is a risk of skidding on wet ground, gravel or uneven terrain.

- Always adjust your speed and driving style to the conditions (weather, surface, individual ability, etc.).



WARNING!

Risk of injury

In a collision you could sustain injury to parts of your body that extend beyond the wheelchair (e.g. feet or hands).

- Avoid an unbraked collision.
- Never drive into an object head-on.
- Drive carefully through narrow passages.



WARNING!

Risk due to wheelchair being out of control

At high speed you could lose control of your wheelchair and overturn.

- Always adjust your driving speed to the given conditions.
- Avoid collisions in general.



WARNING!

Risk of accidents

Safety devices that are incorrectly set or no longer working (brakes, antitipper) can cause accidents.

- Always check that the safety devices are working before you use the wheelchair and have them regularly checked by a qualified technician or your provider.



CAUTION!

Risk of injuries

– In case of pressure sore or injured skin, protect your injury to avoid a direct contact with the fabrics of the device. Refer to a healthcare professional for medical advices.



CAUTION!

Risk of injuries

The use of a manual wheelchair can lead to shoulder pain. The following recommendations reduce this effect:

- Move the rear wheels further forwards so that the arms can move within the anatomical range.
- Make sure that the sits in an ergonomically seat position as the disability allows.



CAUTION!

Risk of burning

The wheelchair components can heat up when exposed to external sources of heat.

- Do not expose the wheelchair to strong sunlight before use.
- Before usage, check all components that come into contact with your skin for their temperature.



CAUTION!

Risk of getting fingers caught

There is always a risk of getting, e.g. fingers or arms, caught in the moving parts of the wheelchair.

- Make sure when activating the folding or insertion mechanisms of moving parts, such as the removable axle of the rear wheel, folding backrest or antitipper, that nothing becomes caught.



CAUTION!

Risk of Injury

Non-original or wrong parts may affect the function and safety of the product.

- Only use original parts for the product in use.
- Due to regional differences, refer to your local Invacare catalog or website for available options or contact your Invacare distributor. See addresses at the end of this document.



IMPORTANT!

When combining this product with another product, the restrictions of both products apply for the combination. E.g. the maximum user weight of one product in the combination may be lower.

- Only use combinations allowed by Invacare. Contact your Invacare distributor for information.
- Before use, read the user manual of each product and check the restrictions.

2.2 Labels and Symbols on the Product

Identification Label

The identification label is attached to the frame of your wheelchair and gives the following information:

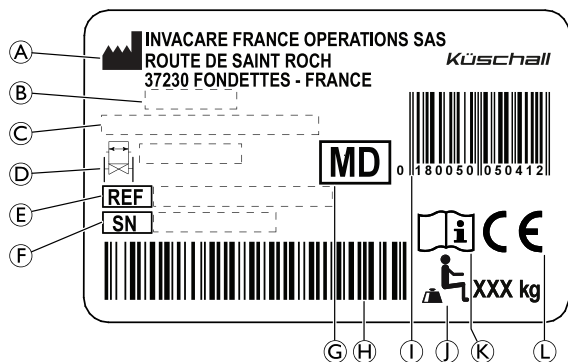

Ⓐ	Manufacturer's address
Ⓑ	Date of manufacture
Ⓒ	Product description
Ⓓ	Seat width
Ⓔ	Reference number
Ⓕ	Serial number
Ⓖ	Medical device
Ⓕ	Serial number barcode
Ⓘ	EAN/HMI barcode
Ⓙ	Maximum user weight
Ⓚ	Read user manual
Ⓛ	European conformity

Snap Hook Symbol



Tie-down positions where the restraint system straps must be placed in case of transporting the occupied wheelchair in a motor vehicle, see 6.9 *Transporting the occupied wheelchair in a vehicle*, page 41.

This symbol is only attached to the wheelchair when it is ordered with the transportation kit option.



WARNING Symbol

This wheelchair is not configured for passenger transport in a motor vehicle.

Antitipper Warning Label



WARNING: Read user manual

Follow user manual instructions prior to the usage of an antitipper device.

Non-locking Side Parts Warning Label



Do not lift the wheelchair by non-locking side parts.

Stabilizing Bar Warning Label

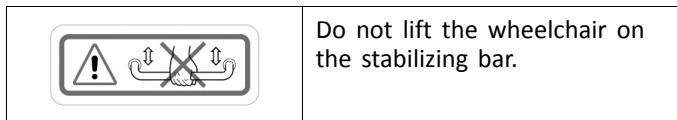

3 Product Overview

3.1 Intended Use

The wheelchair is intended to provide mobility to persons limited to a sitting position, who are propelling the wheelchair themselves most of the time.

The intended user is the wheelchair occupant and/or an assistant. The user should physically and mentally be able to use the wheelchair safely (e.g. to propel, steer, brake).

The wheelchair is intended for persons, ages 12 and up (adolescents and adults). The weight of the wheelchair occupant should not exceed the maximum user weight as stated in the Technical Data section and on the identification label.

The wheelchair is not intended for abusive or excessive activities, such as sports, that are not part of the intended (daily) use.

The wheelchair may be used indoors and outdoors on level ground and accessible terrain.

Indications

- Considerable to complete impairment of mobility due to structural and/or functional damage to the lower extremities.
- Sufficient strength and gripping function of arms and hands to propel the wheelchair.

There are no contraindications known, when using the wheelchair as intended.

3.2 Product description

Compact SA is a folding active wheelchair with cross struts and swing-away leg rests.

Compact FF is a folding active wheelchair with cross struts.



IMPORTANT!

The wheelchair is manufactured and configured individually to the specifications in the order. The specification must be performed by a healthcare professional according to the user's requirements and health condition.

- Consult a healthcare professional if you intend to adapt the wheelchair configuration.
- Any adaptation must be performed by a qualified technician.

3.3 Main parts of the wheelchair

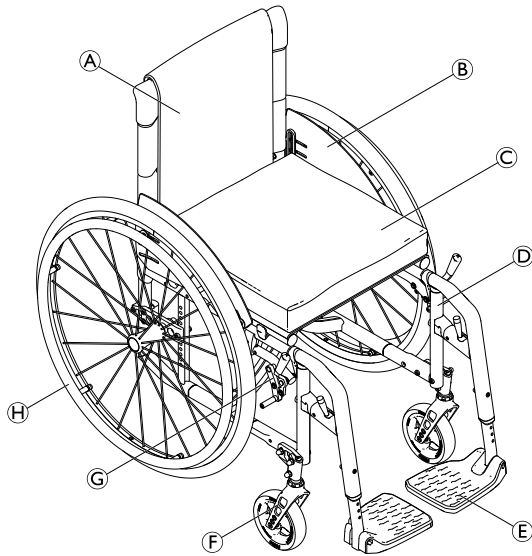

(A)	Backrest
(B)	Clothes-guard
(C)	Seat with cushion
(D)	Frame
(E)	Footrest
(F)	Castor fork with castor wheel
(G)	Parking brake
(H)	Rear wheel with handrim and quick-release axle

 The equipment of your wheelchair may differ from the image as each wheelchair is manufactured individually to the specifications in the order.

3.4 Parking Brakes

The parking brakes are used to immobilise the wheelchair when it is stationary to prevent it from rolling away.



WARNING!

Risk of Overturning if you brake sharply

If you engage the parking brakes while you are moving, the direction of movement can become uncontrollable and the wheelchair may stop suddenly, which can lead to a collision or to you falling out.

– Never engage the parking brakes while you are moving.



WARNING!

Risk of Overturning

The parking brakes will not operate correctly unless there is sufficient air pressure in the tyres.

- Ensure the correct tyre pressure, see 11.2 Tyres, page 57.

Standard Brake

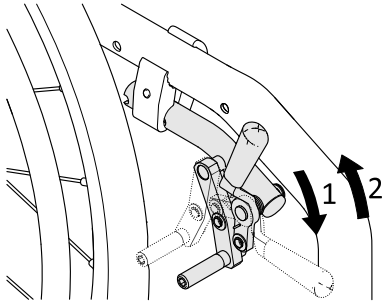

1. To engage the brake, push the brake lever forwards as far as possible.
2. To disengage the brake, pull the brake lever backwards.

Active Brake

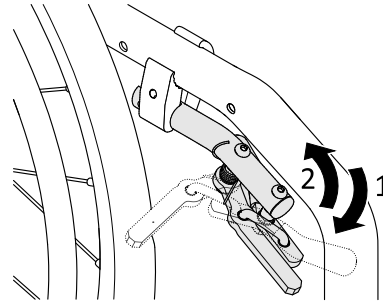

1. To engage the brake, pull the brake lever forwards beside or between your knees as far as possible.
2. To disengage the brake, push the brake lever backwards beside or between your knees.

Pull Brake

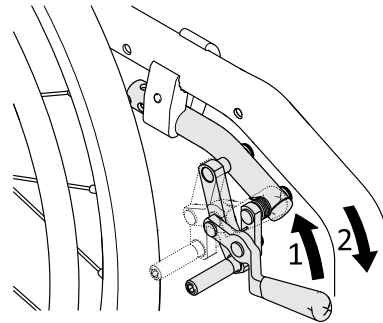

1. To engage the brake, pull the brake lever backwards as far as possible.
2. To disengage the brake, push the brake lever forwards.

Light active Brake

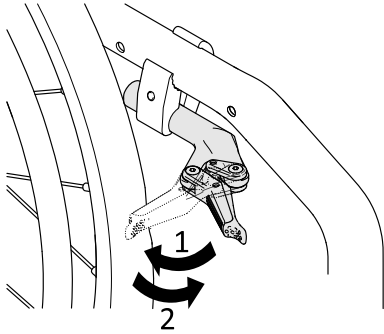

1. To engage the brake, pull the brake lever backwards against the tyre as far as possible.
2. To disengage the brake, push the brake lever forwards.

3.5 Backrest

Backrest Cover

In addition to the non-adjustable backrest cover, there are tension-adjustable backrest covers available.

Adjusting the Tension of the Backrest Cover

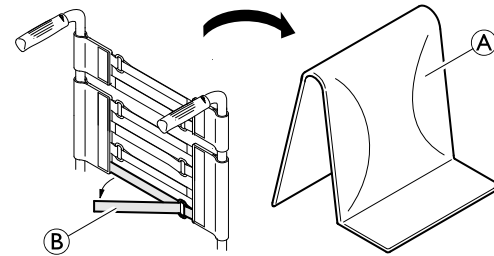

1. Remove the backrest cushion ①.
2. Loosen the hook-and-loop straps ② on the rear of the backrest cover by simply pulling on them.
3. Tighten or loosen the bands as required then reattach them.



WARNING!

Risk of Tipping

If the bands are set very loose, the tipping point of your wheelchair is changed for the worse.
– Ensure that the bands are set correctly.



IMPORTANT!

There is a risk that the geometry of the wheelchair is changed when the bands are overtightened.
– Do not overtighten the bands.
– Only ever tighten the bands when the wheelchair is unfolded.

For folding the backrest, see 7.2 *Folding and unfolding the wheelchair*, page 46.

Backrest Height / Backrest Angle

The height and the angle of the backrest can be adjusted. The adjustment must be carried out by a qualified technician.

3.5.1 Push handles

! IMPORTANT!

- Always check the push handles before using the wheelchair, as to whether the hand grips are secure, cannot be turned and cannot be pulled off.

Foldable push handles

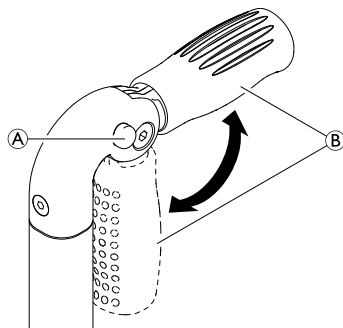

1. Fully depress button (A) and fold up respectively fold down the push handle (B) until it audibly engages.



CAUTION!

If not correctly engaged, the push handle could accidentally fold down while pushing the wheelchair.

- Make sure that the push handle is correctly engaged.

Height-adjustable push handles

The stepless height-adjustable push handles allow any assistant to adjust the handles to a comfortable level.

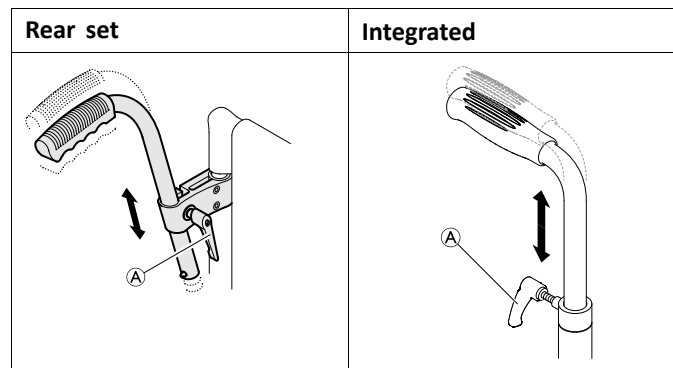

1. To set the height of the push handles, loosen the bolt (A), push the handle to the desired position and tighten the bolt again.



WARNING!

Risk of injury

- Do not use the height-adjustable push handles to pull the wheelchair.

3.6 Folding backrest (optional)

The backrest can be folded down and straightened up when the wheelchair is folded or unfolded.

Folding down the backrest

1. To fold down the backrest, grip the strap on the backrest of the wheelchair and pull it upwards.
2. At the same time, push the upper edge of the backrest forwards.

Folding up the backrest

1. To fold up the backrest, grip the upper edge of the backrest and fold it upwards.

! IMPORTANT!

- Do not fold and unfold the wheelchair when the backrest is folded down.

3.7 Stabilizing bar for the backrest

An optional stabilizing bar is available to increase the rigidity of the backrest on wheelchairs with large back heights or widths.

! IMPORTANT!

- Do not use the stabilizing bar to lift or push the wheelchair. It could break.
- Release the stabilizing bar before folding the wheelchair.

Releasing the stabilizing bar

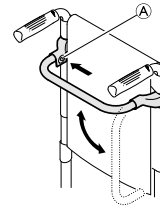

1. Push the spring pin **A** on the fastening on the left-hand side and swivel the stabilizing bar downwards.

The stabilizing bar can also be completely removed, by pushing the spring pins on both sides. The stabilizing bar can then be taken off.

3.8 Side parts

3.8.1 Tubular armrest, non-locking, height-adjustable, removable, swivelling

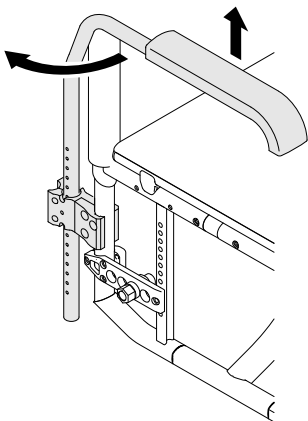

WARNING!

Risk of injury

- The armrests are not locked and can be easily pulled out upwards.
- Do not lift or transfer the wheelchair using the armrests.
 - Do not use the armrests for transportation when carrying the wheelchair up- or downstairs.

Removing

1. Raise the armrest and pull it upwards out of the holder.

Installing

1. Push the armrest into the holder.

1659285-A

Adjusting the height

1. Pull the armrest out of the holder.
2. Loosen the screw on the tube of the armrest and screw it back in at the desired height.
3. Push the armrest back into the holder.
4. Perform the setting on both sides.

Swivelling

1. Slightly raise the armrest and swivel it outwards.

3.8.2 Side rest, stepless height-adjustable, non-locking

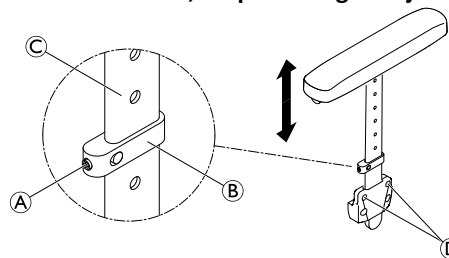

WARNING!

Risk of injury

- The side rests are not locked and can be easily pulled out upwards.
- Do not lift or transfer the wheelchair using the side rests.
 - Do not use the side rests for transportation when carrying the wheelchair up- or downstairs.

Removing

1. Pull the side rest by the arm cushion out of the holder.
2. To adjust how easy or difficult it is to pull the side rest out of the holder, change the degree to which the screws ⑤ are tightened.

Installing

1. Push the side rest into the holder.

Adjusting the height

1. Slightly loosen the grub screw ① on the clamping part ②.
2. Move the clamping part upwards or downwards on the profile ③ to the desired height.
3. Re-tighten the grub screw.
4. Perform the setting on both sides.

3.8.3 Küschall Armrest

This armrest option is locking in place and can be flipped backwards, swivelled outwards and removed. The T-armrest pad is height adjustable and also locks in place.

Removing the Armrest

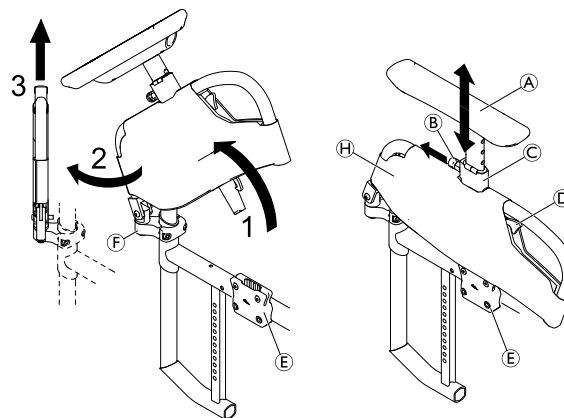

1. Push release lever ① and swivel the armrest assembly upwards out of the armrest holder ②.
2. Swivel the armrest assembly 45° outwards.
3. Pull the armrest assembly upwards out of the joint ③.

Removing the Cover

The cover can be removed to be machine washed at 30° C.

1. Pull out the spring bolt lock ①, grab the T-armrest pad ② and pull it out of the holder ③.
2. Remove the cover ④ from the armrest assembly by opening the hook-and-loop fasteners on both sides.

Installing the Armrest

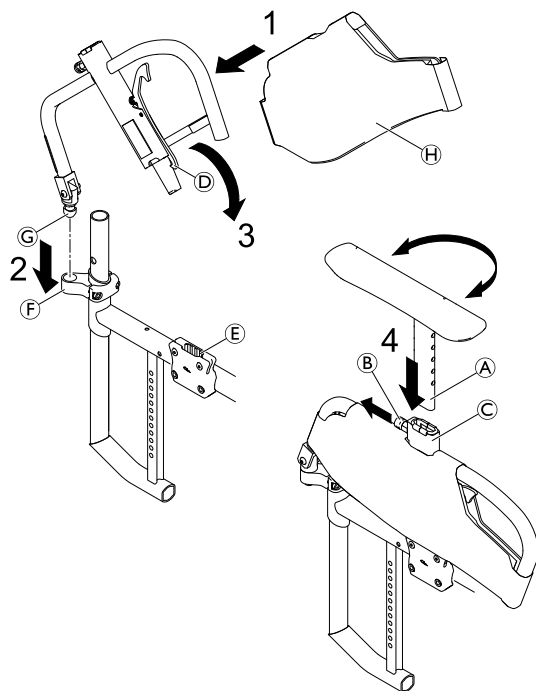

1. Install the armrest cover ④ to the armrest assembly if not yet attached.
2. Insert joint pin ③ of the armrest assembly into the joint ② until it engages with an audible “click”.
3. Swivel the armrest assembly downwards into the armrest holder ① until the release lever hook ④ engages with an audible “click”.

4. Pull out the spring bolt lock ② and insert the bar of the T-armrest pad ① into the holder ③ to the required height.

i The T-armrest pad can optionally be inserted 180° turned.

5. Release the spring bolt lock and allow the bar of the T-armrest pad to engage with an audible “click” in the nearest hole.

Adjusting the Height

1. Pull out the spring bolt lock ② and move the armrest pad ① to the required height.
2. Release the spring bolt lock and allow it to engage with an audible “click” in the nearest hole.



WARNING! **Risk of Injury**

Even if the armrests are locking, they are not designed to carry the weight of the occupied wheelchair.

- Never use the armrests to lift the wheelchair.
- Do not use the armrests for transportation when carrying the wheelchair up- or downstairs.

3.8.4 Mudguard

In order to prevent dirt from the wheels spraying upwards, a removable mudguard can be fitted. The position of the mudguard can be adjusted. The adjustment must be carried out by a qualified technician.

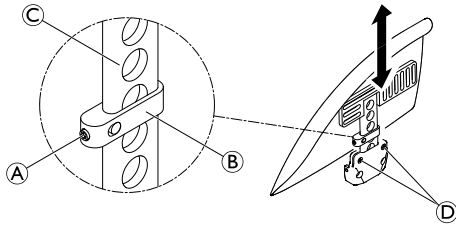

WARNING!
Risk of injury

The mudguards are not locked and can be easily pulled out upwards.

- Do not lift or transfer the wheelchair using the mudguards.
- Do not use the mudguards for transportation when carrying the wheelchair up- or downstairs.

Removing

1. Pull the mudguard upwards out of the holder.
2. To adjust how easy or difficult it is to pull the mudguard out of the holder, change the degree to which the screws (D) are tightened.

Installing

1. Push the mudguard into the holder.

Adjusting the height

1. Slightly loosen the grub screw (A) on the clamping part (B).
2. Move the clamping part upwards or downwards on the profile (C) to the desired height.

3. Re-tighten the grub screw.
4. Perform the setting on both sides.

3.8.5 Clothes-guard

A clothes-guard can be installed to protect your clothes.

3.9 Leg rests



WARNING!
Risk of injury

– Never use the legrests or foot plates to lift the wheelchair.

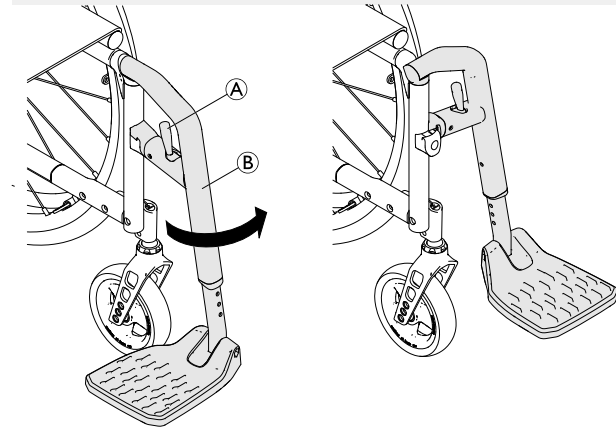

Swivelling

1. Activate the release lever (A) and swivel the leg rest (B) to the outside.

Swivelling forwards

1. Swivel the leg rest forwards until it engages.

Unhinging

1. Activate the release lever .
2. Pull the leg rest upwards.

Hinging

1. Hinge the leg rest on the front of the frame and swivel it forwards until it engages.

3.10 Seat cushion

A suitable cushion is needed to provide an even pressure distribution on the seat.



CAUTION!

Risk of instability

Adding a cushion to the seat will raise your height above the ground and can affect your stability in all directions. If a cushion is changed it may also change the user's stability.

- If the thickness of the cushion is changed, a complete set up of the wheelchair need to be done by a qualified technician.



Use a seat cushion with anti-slip underlay or hook fastening tapes to avoid slipping of the seat cushion. A loop fastening tape is pre-attached to the seat cover.

4 Options

4.1 Antitipper

An antitipper prevents the wheelchair from tipping backwards.



WARNING!

Risk of overturning

Antitippers that are incorrectly set or no longer working can lead to overturning.

- Always check that the antitipper is working before using the wheelchair and have it set or readjusted by a qualified technician when required.



WARNING!

Risk of overturning

On uneven or soft ground, the antitipper can sink into potholes or directly into the ground, thereby curtailing or eliminating its safety function.

- Only use the antitipper when travelling on even and firm ground.

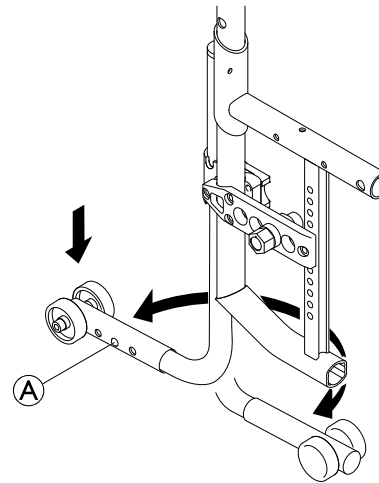

Activating the antitipper

1. Push the antitipper completely downwards and swivel it backwards until it engages.



WARNING!

Risk of tipping

An activated antitipper can catch when negotiating a step or an edge.

- Always deactivate the antitipper before driving over a step or kerb.

Deactivating the antitipper

1. Push the antitipper completely downwards and swivel it forwards until it engages.

Setting the height

1. Press the spring pin  on the antitipper and push the outer section to the position required. Allow the spring pin to engage in the nearest hole.



If further adjustments of height and/or position are necessary, refer to a qualified technician.

4.2 Posture belt

The wheelchair can be equipped with a posture belt. It prevents the user from sliding downward in the wheelchair or from falling out of the wheelchair. The posture belt is not a positioning device.



WARNING!

Risk of serious injury / strangulation

A loose belt can allow the user to slip down and create a risk of strangulation.

- The posture belt should be mounted by a qualified technician and fitted by the responsible prescriber.
- Always make sure that the posture belt is tightly fitted across the lower pelvis.
- Each time the posture belt is used, check if it fits properly. Changing the seat and/or backrest angle, the cushion and even your clothes influence the fit of the belt.

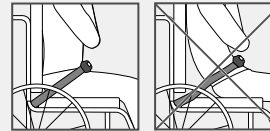

**WARNING!****Risk of serious injury during transport**

In a vehicle, a user in his wheelchair must be secured by a safety belt (3-point belt). A posture belt only is not sufficient as a personal restraint device.

- Use the posture belt as a complement, but not as a substitute to the 3-point safety belt, when transporting the wheelchair user in a vehicle.

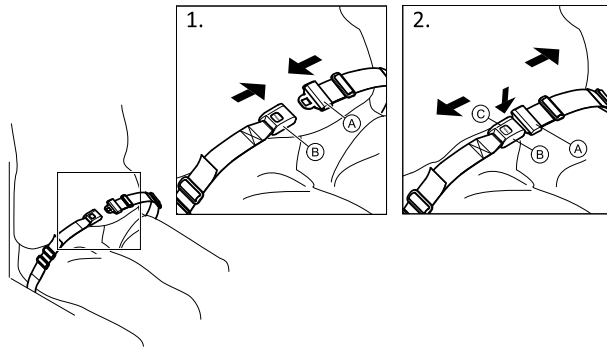
Closing and opening the posture belt

Ensure that you are sitting fully back in the seat and that the pelvis is as upright and symmetrical as possible.

1. To close, push the catch (A) into the buckle clasp (B).
2. To open, push the PRESS button (C) and pull the catch (A) out of the buckle clasp (B).

Adjusting the length

The posture belt has the good length, when there's just sufficient space for a flat hand between body and belt.

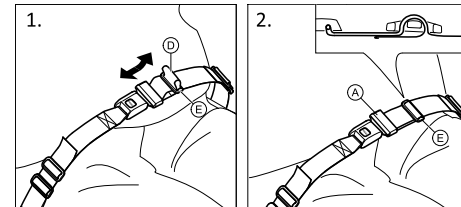

1. Shorten or extend the loop (D) as required.
2. Thread loop (D) through catch (A) and plastic buckle (E) until the loop is flat.

If this adjustment is not sufficient, it might be required to re-fit the posture belt at the fixations.

Fitting the posture belt at the fixations**CAUTION!**

- Thread the belt loop through both plastic buckles to avoid the belt from loosening.
- Do the adjustments on both sides equally, so that the buckle clasp remains in a central position.
- Make sure that the belts do not get caught in the spokes of a rear wheel.

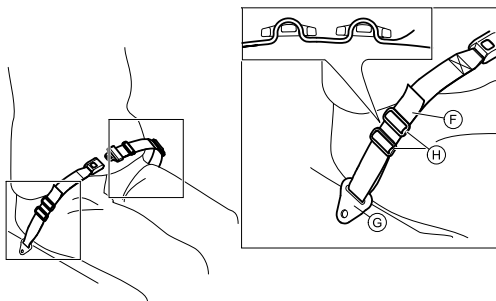

1. Thread the loop (F) through the fixation on the chair (G) and then through BOTH plastic buckles (H).

4.3 Transit wheels

If your wheelchair is too wide for certain applications, e.g. trains/aeroplanes, narrow passageways, narrow doors, the transit wheels can be used.



WARNING!

Risk of severe accidents

- When using transit wheels, the parking brakes no longer have any effect and you cannot control your wheelchair via the handrims.

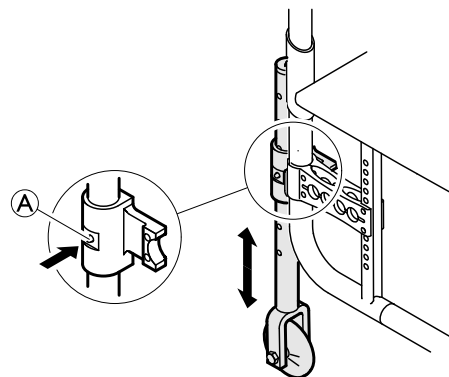

Switching to transit wheels

1. Lower the transit wheels into the operating position. To do this, press the pin (A) inwards until you can pull the tube down.
2. Press the second pin in.
3. Pull the tube further downwards until the pin engages into the slot.
4. Move the wheelchair to a stable object (door frame, heavy table), which you can use for support and hold onto it firmly with one hand.
5. Tilt the wheelchair until the rear wheel on the opposite side rises off the floor.



Prior to removing the rear wheels, the distance between the lowered transit wheels and the floor should not be more than 2 cm.

6. Remove the rear wheel, → 7.3 Removing and Installing the Rear Wheels, page 47.
7. Repeat the process on the other side.

Switching from transit wheels to rear wheels

1. Move the wheelchair to a stable object, which you can use for support and hold onto it firmly with one hand.
2. Tilt the wheelchair until the transit wheel on the opposite side rises slightly off the floor.
3. Install the rear wheel back onto the removable axle, → 7.3 Removing and Installing the Rear Wheels, page 47.
4. Bring the transit wheels back into the inactive position.
5. Repeat the process on the other side.

4.4 Tipper aid

With the tipper aid, an assistant can tip the wheelchair more easily, in order to navigate steps for example.

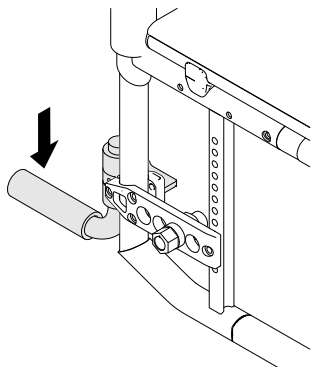

WARNING!

Risk of overturning

– Ensure that the tipper aid does not project beyond the external diameter of the rear wheel.

1. Hold the wheelchair by the push handles.
2. Press the tipper aid with your foot and hold the wheelchair in the tipped position until you have overcome the obstacle.

4.5 Swing away, angle adjustable leg rests

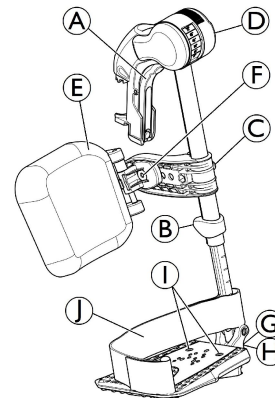

Swinging outwards

1. Activate the release lever ① and swing the leg rests outwards.

Swinging forwards

1. Swing the leg rest forwards until it engages.

Unhinging

1. Activate the release lever **A**, swing the leg rest outwards.
2. Pull the leg rest upwards.

Hinging

1. Push the leg rest down into its receiver and swing it forwards until it engages.

Adjusting angle

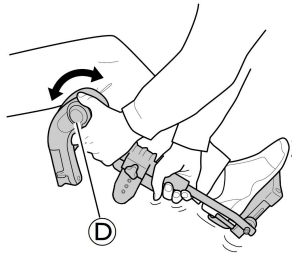

There are six preset positions available for angle adjustment.

1. Rotate the knob **D** with one hand while supporting the leg rest with your other hand.
2. When a suitable angle is obtained, let go off the knob and the leg rest will lock into the desired position.

Swinging calf pad and adjustments

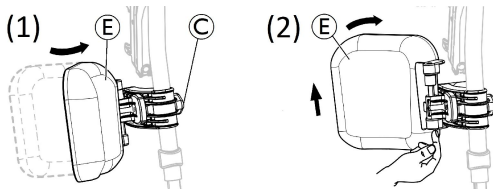

- Swinging calf pad forwards (1) or backwards (2) :
 1. Swing calf pad **E** forwards (1).
 2. Pull up the calf pad **E** and swing it backwards (2).
- Adjusting height of calf pad:
 1. Loosen knob **C**.
 2. Adjust to the desired height and firmly tighten the knob.
- Adjusting depth of calf pad

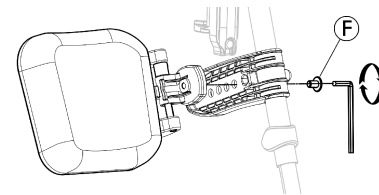

The calf pad has four depth adjustment options:

1. Remove the fixing screw **F** with 5 mm Allen key.
2. Adjust to one of the four positions and firmly tighten the fixing screw **F** (3–5 Nm).

Adjusting foot plate

There are three different fold-up foot plates available.

- Standard height-adjustable foot plates:

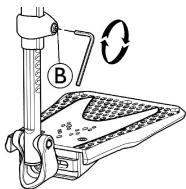

1. Loosen the fixing screw ② with 5 mm Allen key.
2. Adjust the height and let the screw catch one of the recesses on the foot plate tube.
3. Tighten the fixing screw ② (3–5 Nm) in the desired position.

 The distance between the lowest part of the footrest and the ground must be at least 50 mm.

- Depth-, Angle- (1) and Width- (2) adjustable foot plates:

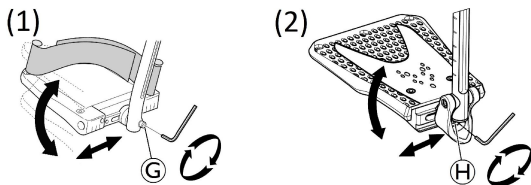

1. Loosen the fixing screw ③ or ④ with 5 mm Allen key.
2. Adjust the depth and angle positions and firmly tighten the fixing screw ③ (12 Nm) or ④ (8–9 Nm) in the desired position.

- Width-adjustable foot plates (2):

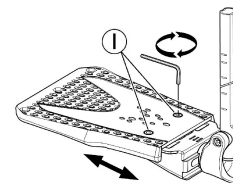

1. Loosen the two fixing screws ⑤ with 5 mm Allen key.
2. Adjust the width position and firmly tighten the two fixing screws ⑤ (3–5 Nm) in the desired position.

Invacare recommends that foot plate adjustment is carried out by a qualified technician.

 To ensure a good position of the feet, two types of straps can be provided; the heel strap ⑥ (serial) and the calf strap (optional) attached to the leg rest support. Both adjustable by hook and loop fasteners.

4.6 Amputee Support



WARNING!

Risk of Tipping

There is an increased risk of tipping for users with amputated legs.

- Use antitippers and/or rebalance the wheelchair when amputee supports are used.

**WARNING!****Risk of Falling**

The wheelchair can tip forwards when getting into the wheelchair and applying load on the amputee support.

- Never sit or lean on the amputee support.

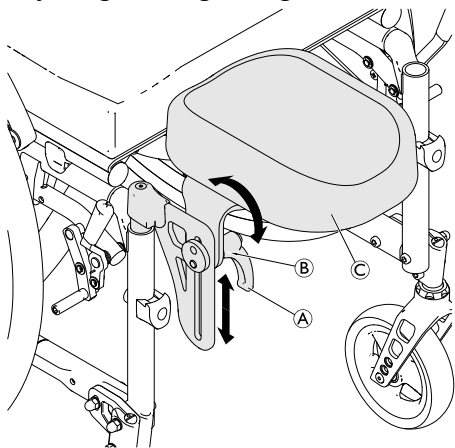
Adjusting the Angle/Height

1. Loosen the lever **A** by turning it counterclockwise.
2. Loosen the nut **B** by turning it counterclockwise.
3. Adjust the desired angle and height of the amputee support **C**.
4. Re-tighten the lever and nut.

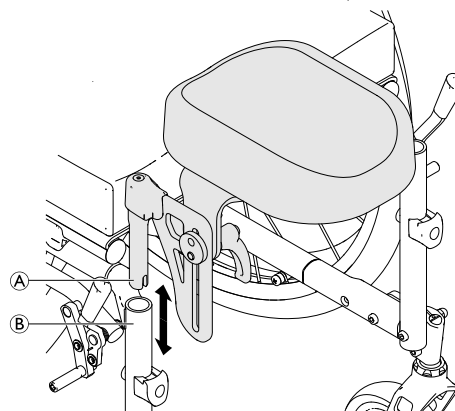
Removing/Installing

1. Remove the amputee support **A** by simply pulling it out of the frame tube **B**.
2. Insert the amputee support by pushing it completely into the holder.

4.7 One arm drive

The one arm drive enables you to move the wheelchair with one hand, which means that two handrims are installed on the same wheel.

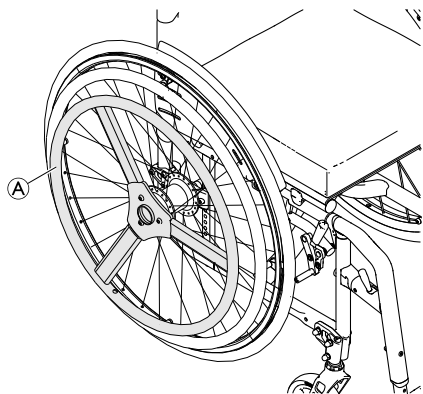

 The drive wheel **A** can be fitted on either the right or the left side of the wheelchair.

 The hand rims can either be placed in line with each other (internal position) or with the inner, smaller, hand rim outside the larger hand rim (external position).

4.8 Cane holder

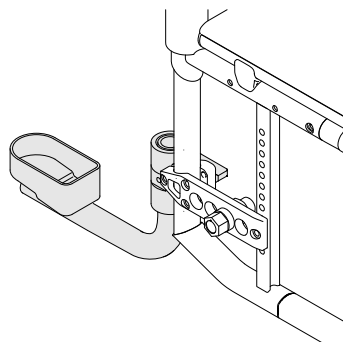

WARNING!

Risk of overturning

– Ensure that the cane holder does not project beyond the external diameter of the rear wheel.



IMPORTANT!

Risk of damage

– Never step on the cane holder or use it as a tipping aid.

1. Place the cane in the holder.
2. Fix the top of the cane to the backrest.

4.9 Luggage carrier

Your wheelchair can be fitted with a luggage carrier. When not in use, the luggage carrier can be folded up.



WARNING!

Risk of tipping

Weight on the carrier changes the tipping behaviour of the wheelchair. The wheelchair can tip forwards more easily when the luggage carrier is loaded.

- Use the luggage carrier only for transporting small and lightweight luggage.
- Avoid driving the wheelchair to fast when carrying luggage.
- Avoid driving ramps and slopes when carrying luggage.
- Do not stand on the luggage carrier.

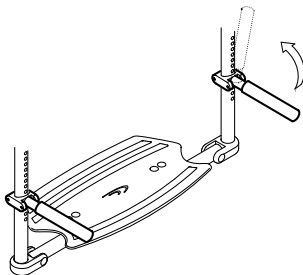

4.10 Calf Strap / Heel Loop

A calf strap and/or heel loops are installed to the leg rests of the wheelchair to provide a better position of the users' legs.

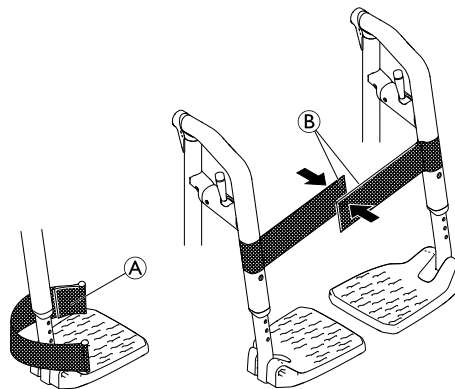

Adjusting the Heel Loops

1. Adjust the heel loops (A) to the desired depth using the hook-and-loop fasteners.

Installing/adjusting the Calf Strap

1. Completely unfold the wheelchair.
2. Close the calf strap by placing both hook-and-loop straps (B) on top of each other.

4.11 Air pump

The air pump is fitted with a universal valve connection.

1. Remove the dust cap from the valve connection.
2. Push the valve connection onto the open valve on the wheel and pump the wheel up.

4.12 Passive illumination

You can attach reflectors to the rear wheels.

5 Setup

5.1 Safety information



CAUTION!

Risk of injury

- Before using the wheelchair, check its general condition and its main functions, 8.2 *Maintenance Schedule, page 48.*

Your provider will supply your wheelchair ready for use. Your provider will explain the main functions and ensure that the wheelchair meets your needs and requirements.

Adjustments of the axle position and the castor supporters must be carried out by a qualified technician.

If you receive your wheelchair folded, read section 7.2 *Folding and unfolding the wheelchair, page 46.*

6 Usage

6.1 Safety information



WARNING!

Risk of accidents

Uneven tyre pressure can have a huge effect on handling.

- Check the tyre pressure before each journey.



WARNING!

Risk of falling out of the wheelchair

When using small castors the wheelchair could get stuck at curbs or in floor grooves.

- Make sure that the castors are suitable for the surface you are driving on.



CAUTION!

Risk of crushing

There may be a very small gap between the rear wheel and the mudguard or the parking brake with the risk that you could trap your fingers.

- Ensure that you always propel your wheelchair using the handrims only.

Theft and metal detection systems

In seldom cases the materials used in the wheelchair may activate theft and metal detection systems.

6.2 Braking during Use

Whilst you are moving, you brake by transferring force to the handrim with your hands.



WARNING!

Risk of overturning

If you apply the parking brakes while you are moving, the direction of movement can become uncontrollable and the wheelchair may stop suddenly, which can lead to a collision or to you falling out.

- Never apply the parking brakes while you are moving.



WARNING!

Risk of falling out of the wheelchair

If the wheelchair is rapidly decelerated by an assistant pulling at the push handles, the user may fall out of the wheelchair.

- Always apply the posture belt if present.
- Make sure your assistant has been trained individually in transferring occupied wheelchairs.



CAUTION!

Risk of burning your hands

If you brake for a long time, a lot of frictional heat is produced at the handrims.

- Wear suitable gloves.

1. Hold the handrims and press evenly with both hands until the wheelchair stops.

Braking with an attendant

With an attendant's brake (drum brake) an attendant can brake the wheelchair while it is moving. The attendant's brake can also be used as a parking brake.

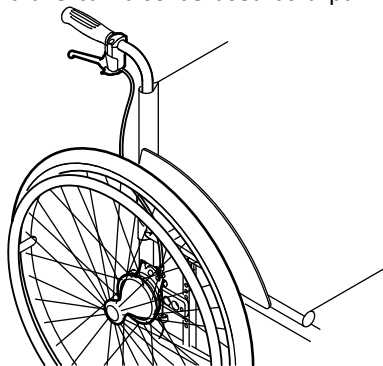

1. To brake, pull the brake lever on the push handle.
2. To park, pull the brake lever firmly until the safety lever engages.
3. To release, pull the brake lever and release the safety lever underneath the brake lever.

6.3 Getting in and out of the wheelchair



WARNING!

Risk of overturning

There is a high risk of overturning during the transfer.

- Only get in and out without assistance if you are physically able to do so.
- When transferring, position yourself as far back as possible in the seat. This will prevent damaged upholstery and the possibility of the wheelchair tipping forward.
- Make sure that both castors are facing straight to the front.



WARNING!

Risk of overturning

The wheelchair could tip forwards if you stand on the footrest.

- Never stand on the footrest when getting in and out.



CAUTION!

If you release or damage the brakes the wheelchair could roll away out of control.

- Do not support yourself on the brakes when getting in and out.

! **IMPORTANT!**

The mudguards and armrests could become damaged.

- Never sit on the mudguards or armrests when getting in and out.



1. Propel the wheelchair as near as possible to the seat that you want to move to.
2. Apply the parking brakes.
3. Remove the armrests or move them upwards out of the way.
4. Detach the legrests or swing them outwards.
5. Place your feet on the ground.
6. Hold the wheelchair and, if necessary, also hold a fixed object in the vicinity.
7. Move slowly to chair.

6.4 Driving and Steering the Wheelchair

You drive and steer the wheelchair using the handrims. Before driving without an assistant you must find your wheelchair's tipping point.

**WARNING!****Risk of Tipping**

The wheelchair can tip backwards if it is not fitted with an antitipper. When finding the tipping point, an assistant must stand immediately behind the wheelchair to catch it if it tips over.

- To prevent tipping, install an antitipper device.

**WARNING!****Risk of Tipping**

The wheelchair can tip forwards.

- When setting up your wheelchair, test its behavior in terms of tipping forward and adjust your driving style accordingly.

**CAUTION!**

A heavy load hanging on the backrest can affect the wheelchair's centre of gravity.

- Change your driving style accordingly.

Finding the Tipping Point



1. Release the brake.
2. Roll backwards a short distance, grasp both handrims firmly and push forwards with a slight kick.
3. The shift in weight and steering in opposite directions with the handrims will enable you to identify the tipping point.

6.5 Negotiating steps and kerbs



WARNING!

Risk of overturning

When negotiating steps you could lose your balance and tip the wheelchair over.

- Always approach steps and kerbs slowly and carefully.
- Do not go up or down steps that are higher than 25 cm.



CAUTION!

An activated antitipper prevents the wheelchair from tipping backwards.

- Deactivate the antitipper before going up or down steps or kerbs.

With an assistant



Going down a step

1. Move the wheelchair right up to the kerb and hold the handrims.
2. The assistant should hold both push handles, place one foot on the tipper aid (if installed) and tilt the wheelchair backwards so that the front wheels lift off the ground.
3. The assistant should then hold the wheelchair in this position, push it carefully down the step and then tilt it forwards until the front wheels are back on the ground.

Going up a step



WARNING!

Risk of serious injuries

Going up steps and kerbs frequently can result in earlier than expected fatigue break of the wheelchair backrest. The user might fall out of the wheelchair.

- Always use a tipper aid when going up steps or kerbs.

1. Move the wheelchair backwards until the rear wheels touch the kerb.
2. The assistant should tilt the wheelchair using both push handles so that the front wheels lift off the ground, then pull the rear wheels over the kerb until the front wheels can be placed back on the ground.

Without an assistant

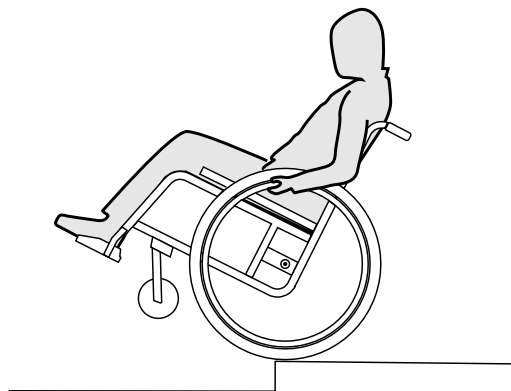

WARNING!

Risk of tipping

When going down a step without an assistant you could tip over backwards if you cannot control your wheelchair.

- First learn how to go down a step with an assistant.
- Learn how to balance on the rear wheels, *6.4 Driving and Steering the Wheelchair, page 35.*

Going down a step

1. Move the wheelchair right to the kerb, lift the front wheels and keep the wheelchair balanced.
2. Now slowly roll both rear wheels over the kerb. While doing this, hold the handrims firmly with both hands until the front wheels are back on the ground.

6.6 Going up and down stairs



WARNING!

Risk of overturning

When negotiating stairs you could lose your balance and overturn your wheelchair.

- Always use two assistants when negotiating stairs with more than one step.



1. You can go up and down stairs by taking them one step at a time, as described above. The first assistant should stand behind the wheelchair holding the push handles. The second assistant should hold a solid part of the front frame to steady the wheelchair from the front.

6.7 Negotiating ramps and slopes



WARNING!

Risk due to wheelchair being out of control

When negotiating slopes or gradients your wheelchair could tip backwards, forwards or sideways.

- Always have an assistant behind the wheelchair when approaching long slopes.
- Avoid lateral slopes.
- Avoid slopes of more than 7°.
- Avoid jerking when changing direction on a slope.



CAUTION!

Your wheelchair could run away even on slightly sloping ground if you do not control it using the handrims.

- Use the parking brakes if your wheelchair is stationary on sloping ground.

Going up slopes

To go up a slope, you must create some momentum, keep up the momentum and control the direction at the same time.

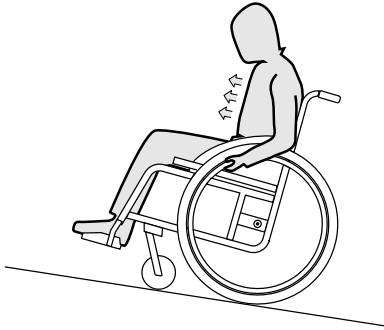

1. Bend your upper body forwards and propel the wheelchair with quick, powerful strokes on both handrims.

Going down slopes

When going down slopes, it is important to control your direction and particularly your speed.

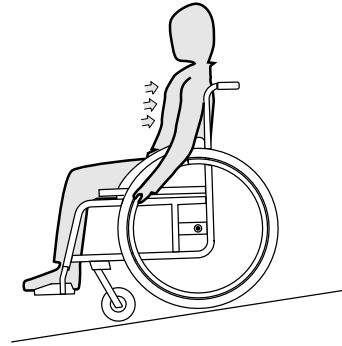

1. Lean back and carefully allow the handrims to run through your hands. You should be able to stop the wheelchair at any time by gripping the handrims.



CAUTION!

Risk of burning your hands.

If you brake for a long time, a lot of frictional heat is produced at the handrims.

– Wear suitable gloves.

6.8 Stability and balance when seated

Some everyday activities and actions require you to lean forwards, sideways or backwards out of the wheelchair. This has a major effect on the wheelchair's stability. To keep your balance at all times, proceed as follows:

Leaning forwards



WARNING! **Risk of falling out**

If you lean forwards out of the wheelchair you could fall out of it.

- Never bend too far forwards and do not shift forwards in your seat to reach an object.
- Do not bend forwards between your knees to pick up something off the floor.

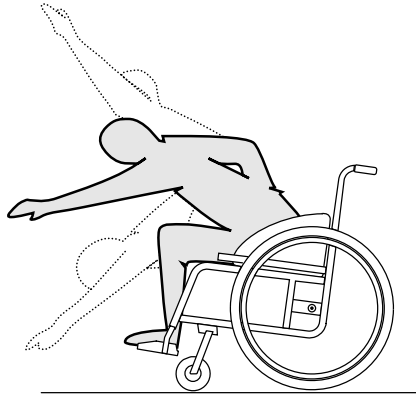

1. Point the front wheels forwards. (To do this, move your wheelchair forwards slightly then back again.)
2. Apply both parking brakes.
3. When leaning forwards your upper body must remain over the front wheels.

Reaching backwards



WARNING! **Risk of falling out**

If you lean too far backwards you could tip your wheelchair over.

- Do not lean out over the backrest.
- Use an antitipper device.

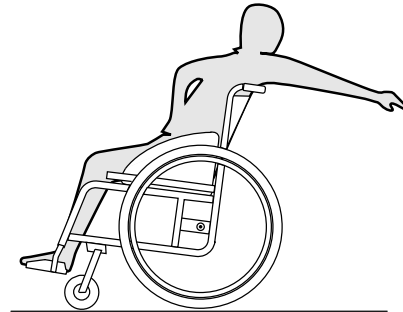

1. Point the front wheels forwards. (To do this, move your wheelchair forwards slightly then back again.)
2. Do not apply the parking brakes.
3. When reaching backwards do not reach so far that you have to change your sitting position.

6.9 Transporting the occupied wheelchair in a vehicle

Even when the wheelchair is properly secured and the following rules are met, injuries to passengers may occur in a collision or sudden stop. Therefore Invacare strongly recommends transferring the wheelchair user to the vehicle seat with the seat belt on. Do not make alterations or substitutions to points of the wheelchair (structure, frame or parts) without the written consent of Invacare. The wheelchair has been successfully tested according to the requirements of ISO 7176-19.



WARNING!

Risk of serious injury or death

To use the wheelchair as a seat in a vehicle the backrest height must be at least 400 mm.

To transport the wheelchair with user in a vehicle, a restraint system must be installed in the vehicle. Wheelchair tie-downs and occupant restraint systems must be approved according to ISO 10542-1. Contact your Invacare representative or your provider for more information on getting and installing an approved and compatible restraint system.



WARNING!

If, for some reason, it is impossible to transfer the wheelchair user to a vehicle seat, the wheelchair can be used as a seat in a vehicle if the following procedures and regulations are followed. A transportation kit (optional) has to be fitted on the wheelchair for such a purpose.

- The wheelchair must be secured in the vehicle with a 4-point wheelchair restraint system.
- The user must wear a 3-point passenger restraint system secured to the vehicle.



WARNING!

Safety restraint devices must only be used when the wheelchair user's weight is 22 kg or more (ISO-7176-19).

- Do not use the wheelchair as a seat in a vehicle when the user weight is lower than 22 kg.



WARNING!

- Before journey contact transporter and request information about the capability for the below required equipment.
- Make sure there is sufficient free space around the wheelchair and user to avoid the user making contact with other vehicle occupants, unpadded parts of the vehicle, wheelchair options or anchor points of the restraint system.
- Take care when applying the occupant restraint to position the seat belt buckle so that the release button will not be contacted by wheelchair components during a crash.



WARNING!

- Make sure the tie-down points at the wheelchair are not damaged and that the parking brakes are fully functional.
- It's recommended to use puncture-proof tyres during transport to avoid brake problems due to reduced tyre pressure.



WARNING!

- Injury or damage may occur from wheelchair components or options loosened during a collision or sudden stop.
- Ensure all removable or detachable components and options are removed from the wheelchair and securely stored in the vehicle.
- It is essential to have your wheelchair checked by your provider after an accident, collision etc.



IMPORTANT!

- Make sure that the restraint system is operated by a qualified person.
- Refer to the user manuals supplied with the restraint systems.
- The following illustrations may differ depending on the restraint system supplier.

Securing the wheelchair with a 4-point restraint system

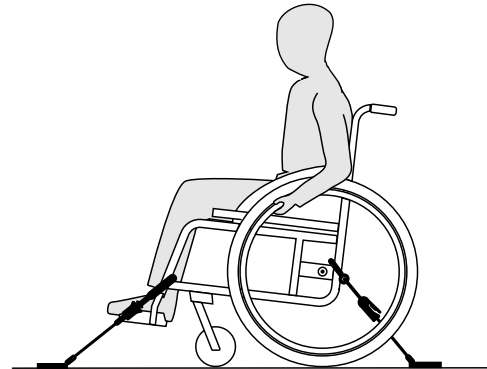

WARNING!

- Place the wheelchair with the user forward-facing in direction of vehicle travel.
- Apply the wheelchair parking brakes.
- Activate antitipper (if installed).

The wheelchair tie-down positions where the restraint system straps must be placed are marked with snap hook

symbols (see following figures and section 2.2 *Labels and Symbols on the Product, page 8*).

1. Using the front and rear straps of the 4-point restraint system, secure the wheelchair to the vehicle mounted rails. Refer to the user manual supplied with 4-point restraint system.

Front side tie-down positions for belt straps:

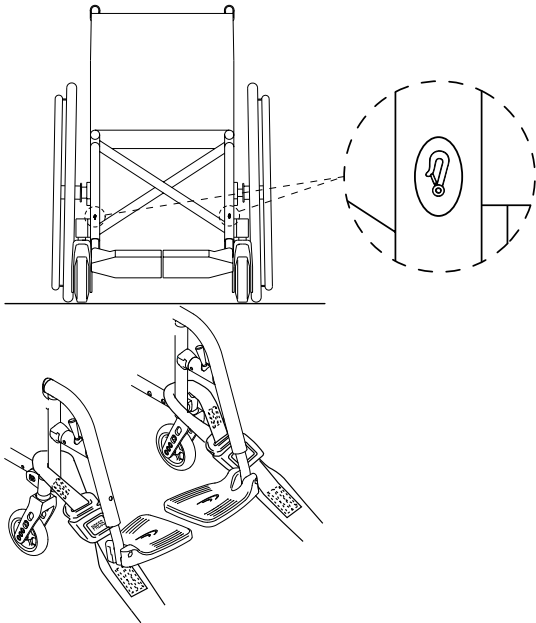

1. Attach the front straps above the castor supporters as shown in the two figures above (see location of the attachment labels).
2. Attach front straps to the rail system referring to best practice recommended instructions from the safety belt manufacturer.
3. Release the parking brakes and apply tension front straps by pulling the wheelchair backwards from the rear.
4. Readjust the parking brakes.

Rear side tie-down positions for snap hooks:

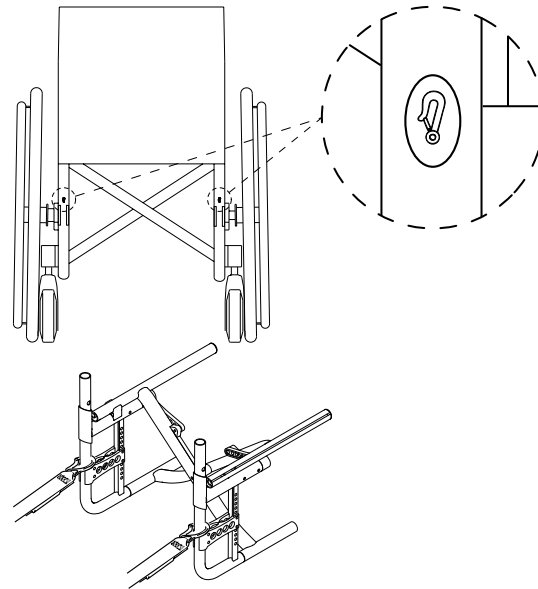

1. Attach rear straps to the rail system referring to best practice recommended instructions from the safety belt manufacturer.
2. Tighten the straps.

! **IMPORTANT!**

- Make sure that the snap hooks are covered with slip resistant material to avoid laterally slipping on the axle.

! **IMPORTANT!**

- Check the plungers are fully engaged on both sides and located in the same position of the cut-out section of the rail.
- Make sure that the angle between the rails and the straps lies between 40° and 45°.

Fastening the 3-point passenger restraint system

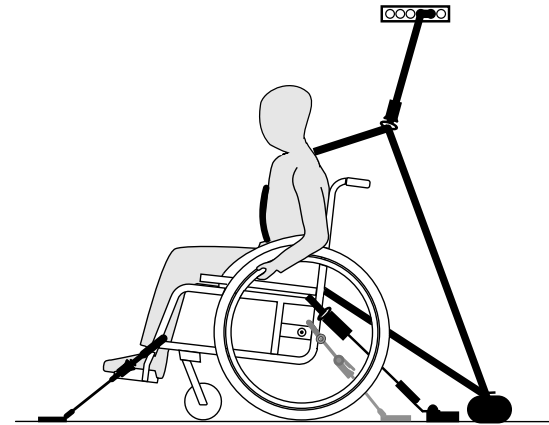

! **IMPORTANT!**

The illustration above may differ depending on the restraint system supplier.

**WARNING!**

- Ensure the 3-point passenger restraint system fits as tightly across the user's body as possible without discomfort and no part is twisted.
- Ensure the 3-point passenger restraint system is not held away from the user's body by parts of the wheelchair such as armrests or wheels etc.
- Ensure the user restraint has a clear path from the user to the anchor point without interference by any part of the vehicle, wheelchair or seating.
- Ensure the lap belt fits snugly over the occupant's pelvis and is not allowed to ride up into the abdominal area.
- Ensure the user is able to reach the release mechanism unaided.

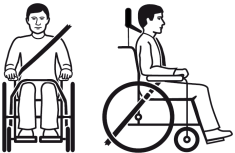

1. Attach the 3-point passenger restraint system referring to the user manual supplied with your 3-point restraint system.

**IMPORTANT!**

- Apply the lap belt of the 3-point passenger restraint system low across the pelvis so that the angle of the lap belt is within the preferred zone (A) of 30° to 75° to the horizontal. A steeper angle is preferred, but never exceeding 75°.

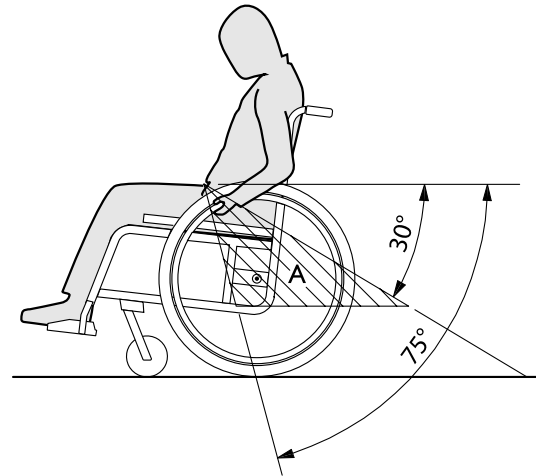

7 Transport

7.1 Safety information



WARNING!

Risk of injury if the wheelchair is not properly secured

In the event of an accident, braking manoeuvre, etc. you may suffer serious injuries from flying wheelchair parts.

- Always remove the rear wheels when transporting the wheelchair.
- Firmly secure all wheelchair components in the means of transport to prevent them from coming loose during the journey.
- When transporting the unoccupied wheelchair in a car or an airplane make sure that it is folded and secured.



IMPORTANT!

Excessive wear and abrasion could affect the strength of load-bearing parts.

- Do not pull your wheelchair across abrasive surfaces without the wheels fitted (e.g. pulling the frame over tarmac).

7.2 Folding and unfolding the wheelchair



IMPORTANT!

- Do not fold and unfold the wheelchair when the back is folded down.

Folding the wheelchair



IMPORTANT!

- Release the stabilizing bar, if present, before folding the wheelchair.

1. Remove the seat cushion, if present.
2. Fold the footrests upwards.
3. Pull the seat cover upwards.
4. Now you can fold the backrest down, if your wheelchair is fitted with a folding back.

Unfolding the wheelchair



CAUTION!

Risk of getting fingers caught

- There is a risk of getting your fingers caught between the seat edge and the frame.
- Never clasp the seat edge with your fingers.

1. Position the wheelchair next to you.
2. If the back is down, fold it up.
3. Tilt the wheelchair, if possible, gently towards you.
4. With your hand flat, press the seat edge closest to you, so that the seat surface flattens out.
5. Put the wheelchair back completely on the floor and check that the seat edges on both sides are in the guide components.
6. Fold the footrests down.

7.3 Removing and Installing the Rear Wheels



WARNING!

Risk of Overturning

If the removable axle of a rear wheel is not fully engaged, the wheel can become loose during use. This can lead to overturning.

- Always ensure that the removable axles are fully engaged whenever you fit a wheel.

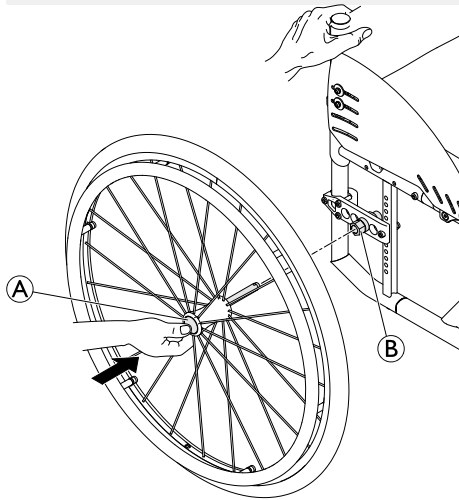

Removing the Rear Wheels

1. Disengage the wheel locks.
2. With one hand, hold the wheelchair upright.

3. With the other, hold the wheel through the external spoke rim around the wheel hub.
4. Using your thumb, press the removable axle button (A). Keep it pressed and pull the wheel out of the adapter sleeve (B).

Installing the Rear Wheels

1. Disengage the wheel locks.
2. With one hand, hold the wheelchair upright.
3. With the other, hold the wheel through the external spoke rim around the wheel hub.
4. Using your thumb, press the removable axle button (A) and hold it down.
5. Push the axle into the adapter sleeve (B) up to the stop.
6. Release the removable axle button and make sure that the wheel is secure.

8 Maintenance

8.1 Safety information



WARNING!

Some materials deteriorate naturally over time. This could result in damage to wheelchair components.

- Your wheelchair should be checked by a qualified technician at least once a year or if it has not been used for a long period.

8.2 Maintenance Schedule

To ensure safe and reliable operation, carry out the following checks and maintenance regularly or have it carried out by another person.

	weekly	monthly	annually
Check the tyre pressure	x		
Check that rear wheels are seated correctly	x		
Check the posture belt	x		
Visual check		x	
Check the castors		x	
Check the bolts		x	

	weekly	monthly	annually
Check the spokes		x	
Check the parking brakes		x	
Have wheelchair checked by your provider			x

Checking the tyre pressure

1. Check the tyre pressure.



See section “Tyres” for more information.

2. Inflate the tyres to the required pressure.
3. Check the tyre tread at the same time.
4. If necessary, change the tyres.

Checking that rear wheels are seated correctly

1. Pull on the rear wheel to check that the removable axle is seated correctly. The wheel should not come off.
2. If the rear wheels are not engaged properly, remove any dirt or deposits. If the problem persists, have the removable axles reinstalled by your provider.

Checking the posture belt

1. Check that the posture belt is adjusted correctly.

! **IMPORTANT!**

- Loose posture belts must be adjusted by your provider.
- Damaged posture belts must be replaced by your provider.
- Posture belts must always be installed by your provider.

Checking visually

1. Examine your wheelchair for loose parts, cracks or other defects.
2. If you find anything, have your wheelchair checked immediately by your provider.

Checking the castors

1. Check that the castors turn freely.
2. Remove any dirt or hair from the castor bearings.
3. Faulty or worn out castors must be replaced by your provider.

Checking the bolts

Bolts can work loose through constant use.

1. Check that the bolts are tight (on the footrest, seat cover, sides, backrest, frame, seat module).
2. Tighten any loose bolts with the suitable torque. Therefore refer to the service manual, available on the internet at www.kuschall.com.

! **IMPORTANT!**

- Self-locking screws/nuts or thread-locking adhesive are used for several connections. If these are loosened, they must be replaced by new self-locking screws/nuts or they must be secured using new thread-locking adhesive.
- Self-locking screws/nuts must be replaced by your provider.

Checking the spoke tension

The spokes should not be loose or distorted.

1. Loose or broken spokes must be tightened by your provider.

Checking the parking brakes

1. Check that the parking brakes are positioned correctly. The parking brake is set correctly if the parking brake shoe depresses the tyre by a few millimeters when the parking brake is engaged.
2. If you find that the setting is not correct, have the parking brakes correctly adjusted by your provider.

! **IMPORTANT!**

- The parking brakes must be readjusted after replacing the rear wheels or changing their position.

Checking after a heavy collision or blow



IMPORTANT!

The wheelchair can sustain visibly undetectable damage as a result of a heavy collision or hard blow.

- It is essential to have your wheelchair checked by your provider after a heavy collision or hard blow.

Repairing or changing an inner tube

1. Remove the rear wheel and release any air from the inner tube.
2. Lift one tyre wall away from the rim using a bicycle tyre lever. Do not use sharp objects such as a screwdriver which could damage the inner tube.
3. Pull the inner tube out of the tyre.
4. Repair the inner tube using a bicycle repair kit or, if necessary, replace the tube.
5. Inflate the tube slightly until it becomes round.
6. Insert the valve into the valve hole on the rim and place the tube inside the tyre (the tube should lie right round the tyre with no creases).
7. Lift the tyre wall over the edge of the rim. Start close to the valve and use a bicycle tyre lever. When doing this, check all the way round to ensure that the inner tube is not trapped between the tyre and the rim.
8. Inflate the tyre to the maximum operating pressure, see *11.2 Tyres, page 57*. Check that no air is escaping from the tyre.

Spare parts



All spare parts can be obtained from your wheelchair provider.

8.3 Cleaning and Disinfection

8.3.1 General Safety Information



CAUTION!

Risk of Contamination

- Take precautions for yourself and use appropriate protective equipment.



IMPORTANT!

Wrong fluids or methods can harm or damage the product.

- All cleaning agents and disinfectants used must be effective, compatible with one another and must protect the materials they are used to clean.
- Never use corrosive fluids (alkalines, acid etc.) or abrasive cleaning agents. We recommend an ordinary household cleaning agent such as dishwashing liquid, if not specified otherwise in the cleaning instructions.
- Never use a solvent (cellulose thinner, acetone etc.) that changes the structure of the plastic or dissolves the attached labels.
- Always make sure that the product is completely dried before taking it into use again.



For cleaning and disinfection in clinical or long-term care environments, follow your in-house procedures.

8.3.2 Cleaning Intervals



IMPORTANT!

Regular cleaning and disinfection enhances smooth operation, increases the service life and prevents contamination.

Clean and disinfect the product

- regularly while it is in use,
- before and after any service procedure,
- when it has been in contact with any body fluids,
- before using it for a new user.

8.3.3 Cleaning



IMPORTANT!

- The product does not tolerate cleaning in automatic washing plants, with high-pressure cleaning equipment or steam.



IMPORTANT!

Dirt, sand and seawater can damage the bearings and steel parts can rust if the surface is damaged.

- Only expose the wheelchair to sand and seawater for short periods and clean it after every trip to the beach.
- If the wheelchair is dirty, wipe off the dirt as soon as possible with a damp cloth and dry it carefully.

1. Remove any installed optional equipment (only optional equipment which does not require tools).
2. Wipe down the individual parts using a cloth or soft brush, ordinary household cleaning agents (pH = 6 - 8) and warm water.
3. Rinse the parts with warm water.
4. Thoroughly dry the parts with a dry cloth.



Car polish and soft wax can be used on painted metal surfaces to remove abrasions and restore gloss.

Cleaning upholstery

For cleaning upholstery refer to the instructions on the labels of the seat, cushion and backrest cover.

8.3.4 Disinfection



Information on recommended disinfectants and methods can be found on <https://vah-online.de/en/for-users>.

1. Wipe down all generally accessible surfaces with a soft cloth and ordinary household disinfectant.
2. Allow the product to air-dry.

9 After Use

9.1 Storage



IMPORTANT!

Risk of damage to the product

- Do not store the product near heat sources.
- Never store other items on top of the wheelchair.
- Store the wheelchair indoors in a dry environment.
- Refer to temperature limitation in chapter *11.4 Environmental conditions, page 58*.

After long-term storage (more than four months) the wheelchair must be inspected in accordance to chapter *8 Maintenance, page 48*.

9.2 Reconditioning

This product is suitable for reuse. To recondition the product for a new user, carry out the following actions:

- Inspection
- Cleaning and disinfection
- Adaptation to the new user

For detailed information, see *8 Maintenance, page 48* and the service manual for this product.

Make sure that the user manual is handed over with the product.

If any damage or malfunction is detected, do not reuse the product.

9.3 Disposal

Be environmentally responsible and recycle this product through your recycling facility at its end of life.

Disassemble the product and its components, so the different materials can be separated and recycled individually.

The disposal and recycling of used products and packaging must comply with the laws and regulations for waste handling in each country. Contact your local waste management company for information.

10 Troubleshooting

10.1 Safety information

Faults may arise as a result of daily use, adjustments or changing demands on the wheelchair. The table below shows how to identify and repair faults.

Some of the actions listed must be carried out by a qualified technician. These are indicated. We recommend that *all* adjustments are carried out by a qualified technician.

**CAUTION!**

– If you notice a fault with your wheelchair, e.g. a significant change in handling, stop using your wheelchair immediately and contact your provider.

10.2 Identifying and repairing Faults

Fault	Possible Cause	Action
The wheelchair does not travel in a straight line	Incorrect tyre pressure on one rear wheel	Correct tyre pressure, → 11.2 Tyres, page 57
	One or more spokes broken	Replace faulty spoke(s), → qualified technician
	Spokes tightened unevenly	Tighten loose spokes, → qualified technician
	Castor supporter is not aligned correctly	Correct position and alignment of the castor supporter, → qualified technician
	Castor bearings are dirty or damaged	Clean or replace the bearings, → qualified technician
	Rear wheels are off track	Change track, → qualified technician
	Castors not adjusted to same height	Position the castors such that they touch the floor at the same time, → qualified technician
The wheelchair tips backwards too easily	Rear wheels are mounted too far forwards	Mount the rear wheels further back, → qualified technician
	Back angle too large	Reduce the backrest angle, → qualified technician
	Seat angle too large	Mount the adapter plate lower on the side profile, → qualified technician Select a smaller castor fork, → qualified technician
Removable axles cannot be inserted correctly	Removable axles dirty	Clean removable axles
	Removable axles misaligned	Adjust removable axles, → qualified technician

Fault	Possible Cause	Action
The parking brakes are gripping poorly or asymmetrically	Incorrect tyre pressure in one or both rear tyres	Correct tyre pressure, → <i>11.2 Tyres, page 57</i>
	Parking brake setting incorrect	Correct the parking brake setting, → qualified technician
Rolling resistance is very high	Tyre pressure in rear tyres is too low Tyre is punctured	Correct tyre pressure or replace the tube inside the tyre, → <i>11.2 Tyres, page 57</i>
	Rear wheels not parallel	Ensure the rear wheels are parallel, → qualified technician
The castors wobble when moving fast	Too little tension in castor bearing block	Tighten the nut on the bearing block axle slightly, → qualified technician
	Castor wheel has worn smooth	Change castor, → qualified technician
The castor is stiff or stuck	Bearings are dirty or faulty	Clean or replace the bearings, → qualified technician
The wheelchair is very difficult to unfold	Backrest cover is too tight	Loosen the hook-and-loop straps of the backrest cover a little, → <i>3.5 Backrest, page 14</i>

11 Technical Data

11.1 Dimensions and Weight

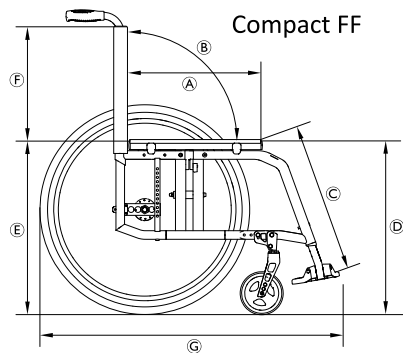
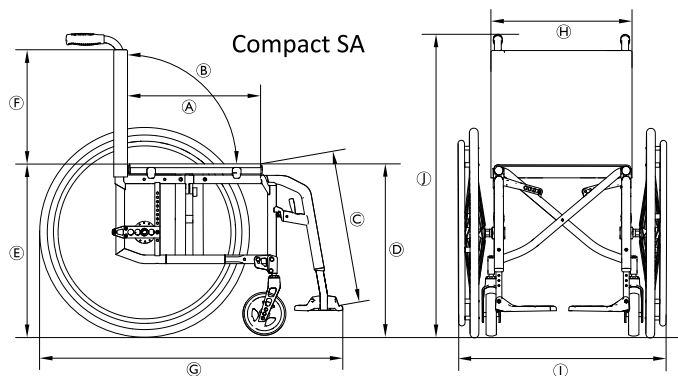

Ⓐ	Seat depth	320 – 500 mm, in increments of 20 mm
Ⓑ	Backrest angle	82°/86°/90°/ 94°/98°/102°
Ⓒ	Lower leg length	200 – 510 mm, in increments of 10 mm
Ⓓ	Front seat-to-floor height	370 – 530 mm, in increments of 10 mm
Ⓔ	Rear seat-to-floor height	360 – 500 mm, in increments of 10 mm
Ⓕ	Backrest height	300 – 510 mm, in increments of 15 mm
Ⓖ	Overall length with legrest	70° frame angle: approx. 870 – 1220 mm 80° frame angle: approx. 850 – 1200 mm
Ⓗ	Seat width	280 – 500 mm, in increments of 20 mm
Ⓘ	Overall width	Seat width + 180 mm
	Overall width, folded	approx. 290 mm
	Folded length	70° frame angle: approx. 870 – 1220 mm 80° frame angle: approx. 850 – 1200 mm
⓵	Overall height	approx. 660 – 1060 mm
	Folded height	approx. 660 – 1060 mm

Total weight Compact SA: Compact FF:	approx. 10.5 kg approx. 9.6 kg
Weight of the heaviest part Compact SA: Compact FF:	approx. 7.8 kg approx. 6.7 kg
Pivot width	1420 mm
Minimum turning radius	950 mm
Max. safe slope	7°
Static stability downhill	20°
Static stability uphill	7°
Static stability sideways	20°
Seat plane angle	0° – 12°
Leg to seat surface angle	100° / 110°
Armrest to seat distance	120 – 280 mm
Front location of armrest structure	220 – 330 mm
Handrim diameter	450 – 590 mm

Horizontal location of axle	approx. –60 to +90 mm
Maximum user weight	130 kg

The wheelchair conforms to ISO 7176-8 and ISO 7176-16.

11.2 Tyres

The ideal tyre pressure depends on the tyre type.

The table below is an indication. In case the tyre differs from the list below, check the side of the tyre, the maximum pressure is often listed there.

Tyre	Diameter and width	Max. pressure		
		7 bar	700 kPa	101 psi
Profile tyre	24x1"			
Schwalbe Marathon Plus	24-25-26x1"	10 bar	1000 kPa	145 psi
Schwalbe One	24-25x1"	10 bar	1000 kPa	145 psi
Schwalbe Righrun	24-25-26x1"	10 bar	1000 kPa	145 psi



The compatibility of the tyres listed above depends on the configuration and/or model of your wheelchair.

 In case of a tyre puncture consult a suitable workshop (e.g. bike repair shop, bicycle dealer ...) to have the tube replaced by a skilled person.

 The size of the tyre is mentioned on the sidewall of the tyre. The change of appropriate tyres must be carried out by a qualified technician.



CAUTION!

– The tyres pressure needs to be equal in both wheels to avoid decreased driving comfort, to keep the parking brakes working properly and to ease propelling of the wheelchair.

11.3 Materials

The components used to manufacture Küschall® wheelchairs consist of following materials:

Frame tubes	Aluminum
Backrest tubes	Aluminum
Cross struts	Aluminum
Seat cover / Backrest cover	PA / PE / PVC
Push handles	Aluminum / TPE
Clothes guard / Mudguard	Carbon Fiber or Plastic
Castor forks	Aluminum
Legrest	Aluminum
Footrest	Carbon Fiber or Plastic

Supporting parts / Attachments	Steel / Aluminum
Screws and bolts	Steel

All components have either a protective coating or are corrosion resistant.

11.4 Environmental conditions

	Storage and transportation	Operation
Temperature	-20 °C to 40 °C	
Relative humidity	20 % to 90 % at 30 °C, not condensing	
Atmospheric pressure	800 hPa to 1060 hPa	

Invacare distributors

Asia:

Invacare Asia Ltd.
1 Lenton Place, North Rocks NSW 2151
Australia
Phone: (61) (02) 8839 5333
Fax: (61) (02) 8839 5343
asiasales@invacare.com
www.invacare.com

Ireland:

Invacare Ireland Ltd,
Unit 5 Seatown Business Campus
Seatown Road, Swords, County Dublin
Tel : (353) 1 810 7084
Fax: (353) 1 810 7085
ireland@invacare.com
www.invacare.ie

United Kingdom:

Invacare Limited
Pencoed Technology Park, Pencoed
Bridgend CF35 5AQ
Tel: (44) (0) 1656 776 222
Fax: (44) (0) 1656 776 220
uk@invacare.com
www.invacare.co.uk

Australia:

Invacare Australia Pty. Ltd.
1 Lenton Place, North Rocks NSW 2151
Australia
Phone: 1800 460 460
Fax: 1800 814 367
orders@invacare.com.au
www.invacare.com.au

New Zealand:

Invacare New Zealand Ltd
4 Westfield Place, Mt Wellington 1060
New Zealand
Phone: 0800 468 222
Fax: 0800 807 788
sales@invacare.co.nz
www.invacare.co.nz



Invacare France Operations SAS
Route de St Roch
F-37230 Fondettes
France

1659285-A 2019-11-18



Making Life's Experiences Possible®

Küschall®
UNLIMIT YOUR WORLD