

en Vereya 80 / 90 cm – User manual

This manual must be given to the user of the product.
Read this manual before using the BUL G1 care bed. Store this manual
close to the bed for future reference.

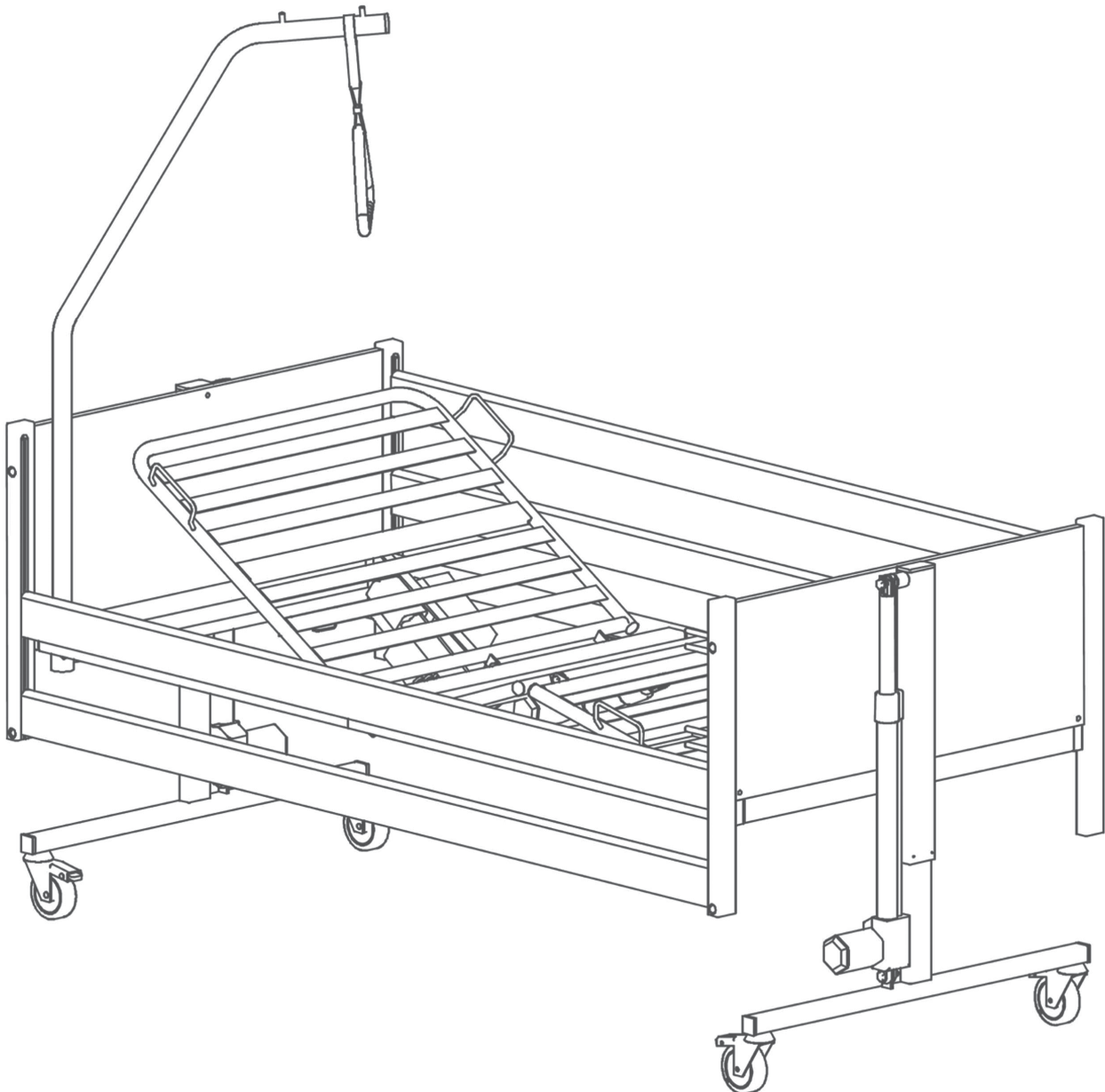

1. ENVIRONMENT AND SAFETY

1.1. Requirements applying to personnel	4
1.1.1. Patient.....	4
1.1.2. User	4
1.1.3. Healthcare professional	4
1.1.4. Technician.....	4
1.2. Description of the bed	4
1.3. Application environment	4
1.4. Description of the target patient group	4
1.5. Target group of patients	4
1.6. Restrictions on use	4
1.6.1. Physical and mental capacity	4
1.6.2. Patients over 185 cm	4
1.7. Undesirable side-effects	4
1.8. <u>Special care regarding the use of side rails and the choice of mattress</u>	4
1.9. Location of the bed in the room	5
1.10. Moving the bed in the room	5
1.11. Transfer in and out of the bed	5
1.12. <u>Operating the movable part of the bed – remote control unit</u>	5
1.12.1. Electrical system	5
1.12.2. Load on the bed	5
1.12.3. The trapeze bar	5
1.12.4. Braking system.....	5
1.12.5. Use of original parts	5
1.12.6. Complaints.....	5

2. OPERATING THE BED

2.1. Check the following points regularly	5
2.2. Locking and unlocking the castors	5
2.3. Moving the bed on wheels	5
2.4. Operating the side rails	6
2.4.1. Wooden side rails	6
2.5. Operating the moving parts of the bed	6
2.5.1. Remote control unit.....	6
2.5.2. Integrated locking system.....	6
2.6. Lower leg rest adjustment	7
2.7. <u>Emergency flat position (bringing the bed into flat position)</u>	7
2.8. <u>Troubleshooting procedure: what to do if the bed actuators malfunction</u>	7

3. ASSEMBLING THE BED

3.1. Unpack and check all the parts	7
3.2. Position the platform actuators	7
3.3. If a bed extension is used	7
3.4. Assembling the bed parts	7
3.5. Assembling the trapeze bar (option)	8
3.6. Assembling the wood rails (option)	8

3.7. Electrical equipment	8
3.7.1. Description	8
3.7.2. Electrical connection.....	8
3.8. Final inspection of the assembly	9
3.9. Moving the bed on wheels	9
3.10. Disassembling the bed	9
3.11. Storage and transport kit	9
3.12. Packaging material disposal	10
3.13. <u>Disposal of components at the end of the bed's useful life</u>	10

4. TECHNICAL SPECIFICATIONS

4.1. Technical data	10
4.2. Mattress characteristics	10

5. MAINTENANCE INSTRUCTIONS

5.1. Inspection and maintenance	10
5.2. Measurement of the general electrical system	10
5.3. Backup battery (if available)	10
5.4. Cleaning and disinfecting	10

6. APPENDIX

6.1. Servicing schedule for the NIPI-M BUL G1 bed	12
6.2. Drawing and description	14
6.2.1. Complete bed	14
6.2.2. BUL G1 platform.....	15
6.2.3. BUL G1 head and foot.....	16
6.2.4. Electrical system.....	17
6.3. Mattress specifications	17
6.4. Warranty	17
6.5. Table of symbols used in the manual or on the bed	18



After examining the patient's needs and environment, a healthcare professional has recommended this bed, with a mattress and accessories, as well as procedures appropriate to the needs of the patient and users.

The bed must be installed by a specialist, who will explain how to use it safely and efficiently.

This manual provides instructions about using, assembling, and maintaining the bed and the associated limitations and risks. Please read it carefully in full before using the bed. Do not hesitate to refer to it as often as necessary. If any additional information needed, consult a healthcare professional and follow their recommendations.

The precautions for use presented in this manual are general warnings. Contact the NIPI-M dealer or a healthcare professional as necessary and follow their advice on use and safety. You will find the address of your NIPI-M contact at the end of the manual.

A thorough understanding of parts 1 and 2 of this manual is required to use this bed.

A thorough understanding of parts 1 to 4 of this manual is required to assemble this bed.

The maintenance of the bed must be performed by specially trained personnel.

NIPI-M reserves the right to make changes without prior notice. Therefore, it is possible that some parts of the text are not applicable or images are slightly amended.



In this manual, the Warning symbol indicates a potentially dangerous situation(s) or hazardous practice(s).

The care bed is guaranteed for a period of:

Bed frame: 2 years

Electrical components: 2 years (excluding the backup battery)

Please refer to the last pages of the manual.

Upon delivery of the bed, please check that the packaging is not damaged and that the contents are complete. Any complaint about visible damage must be made immediately.

With proper operation and maintenance, the bed has an expected service life of 10 years. The service life depends on operating conditions and frequency.

1. ENVIRONMENT AND SAFETY

1.1. Requirements applying to personnel

Only qualified personnel are able to evaluate the risks that could cause personal injury or property damage, and therefore to operate the bed's functions safely.

The different tasks described in this manual require different skills.

If any doubts concerning the safety or correct operation of the bed, stop using it immediately and contact the dealer.

1.1.1. Patient

The patient is defined as any person in need of care or any elderly or disabled person lying on the bed.

1.1.2. User

The user interacts with the functions of the bed and must therefore have a clear understanding of the instructions for use and the safety warnings described in parts 1 and 2 of this manual, and of the possible risks related to the operation of these functions.

Users must therefore read this manually carefully and understand it. They may also benefit from instructions and training provided by medical staff.

The most frequent users are assistants, nurses, cleaning staff and the patient, depending on the healthcare professional's recommendations.

1.1.3. Healthcare professional

Medically qualified personnel trained for the environment in which the bed will be used (the application environment) and with knowledge of the important guidelines, rules and laws concerning the care bed.

After examining the patient's needs and environment, the healthcare professional will recommend a bed and equipment appropriate to the needs of the patient and the user(s).

In some instances, the healthcare professional's team will have to conduct a risk assessment and accept the risks before using the bed, for example:

- with patients who are agitated or confused,
- with patients less than 150 cm tall or weighing less than 50 kg,
- with side rails for patients over 185 cm tall.

Your prescribing doctor is a healthcare professional.

1.1.4. Technician

Person or organization trained and experienced in the mechanical and electrical field, with knowledge of the rules and regulations concerning the assembly, maintenance, and repair of the bed. The NIPI-M dealer is a technician.

12. Description of the bed

The NIPI-M care bed is designed to provide appropriate comfort for the patient's needs in a sitting or lying position, while ensuring a convenient working position for the nursing staff.

13. Application environment

The bed is designed to be used under the following conditions:

- Application environment 3: long-term care where medical supervision is required, and monitoring is provided if needed to help maintain or improve the patient's condition.
- Application environment 4: care provided at home to relieve or compensate for an injury, disability or disease.
- Application environment 5: outpatient (ambulatory) care provided in a hospital or other medical facility, under medical supervision, to treat, diagnose or monitor people with illnesses, injuries or disabilities.



Do not use electronic medical devices on this care bed.

14. Description of the target patient group

The BUL G1 care bed is not designed for all patients. It is important to know and to comply with the following limits on its use.

15. Target group of patients

The bed is specifically designed for patients over 12 years of age with a height between 146 cm and 185 cm, a Body Mass Index (BMI: weight in kg/height in m squared) of 17 or over, and weighing less than 135 kg.

16. Restrictions on use

16.1. Physical and mental capacity

Always take the physical and mental capacities of each patient into account before using the bed.



The bed must not be used for patients with psychiatric disorders.



The bed must not be used for confused, agitated or disoriented patients or patients with impaired judgment unless its use is approved by a healthcare professional following a risk analysis.

16.2. Patients over 185 cm

For patients over 185 cm in height, the bed can be adjusted to 195 cm using one bed extension, and to 205 cm with two bed extensions.

17. Undesirable side-effects

Risks associated with prolonged immobilisation of the patient in a lying position: possible formation of pressure sores, physiopathological and/or metabolic disorders, reduced muscle tone, muscle wasting, bronchial and/or pulmonary disease, digestive disorders (anorexia, constipation, urinary infections or urinary retention), psychological disorders.

Any serious incidents occurring related to the device should be reported to the manufacturer and to the competent authority of the member state in which the user and/or patient lives.

18. Special care regarding the use of side rails and the choice of mattress



The use of side rails must be approved by a healthcare professional following a risk analysis: the patient could climb over the rail and fall on the floor, causing injury.



When using the bed with side rails, extra precautions should be taken to prevent the patient slipping into the space between the side rail and the mattress, with a risk of getting stuck, causing injury or suffocating. Special attention must be taken if the bed is used by patients less than 1.5 m tall.



If the bed is used for patients less than 1.5 m tall or less than 50 kg in weight, the use of the side rails must be approved by a healthcare professional following a risk assessment.



When the sides rails are in the raised position, check that they are correctly locked into position.



When using the side rails, special attention must be given to the psychological risks: a feeling of isolation or trauma.

Check that the side rails are in the required position when the patient is sleeping and/or not being monitored.

The side rails must not be used to lift oneself up or make other movements.

When choosing the mattresses (dimensions, foam density etc.), it is very important to consider the risk of the patient becoming trapped between the mattress and the side rail, or between the mattress and the head or foot of the bed.

The risk of falling over the side rails limits the total height of the mattress: see paragraph 6.3. Mattress specifications.

 **The mattress must satisfy the required characteristics: consult the dealer or a specialist to choose a suitable mattress.**

 **Using the side rails with an incompatible mattress can cause a risk of the patient becoming trapped.**

NIPI-M has tested and recommends the following mattresses: see the table at the end of the manual.

1.9 Location of the bed in the room

Select a location measuring at least 2.5 m x 1.5 m, with a height of 2.2 m, with a flat, stable and horizontal floor, in a dry room free from obstacles, where the bed can be moved freely.

 **The bed must be positioned so that height adjustments are not obstructed. Pay special attention to ceiling height when using a trapeze bar. Pay special attention to windowsills and opening panes when the bed is located close to a window.**

Consider the location of the power supply outlets.

Power supply voltage: 100-240 V 50/60 Hz.

1.10 Moving the bed in the room

This bed is not designed for patient transport. It should only be moved within the patient room for cleaning purposes or patient access.

1.11 Transfer in and out of the bed

Before any patient transfer, take care that the platform is flat, in the lowest position, the side rails are down, the brakes are applied and the remote control is secured.

1.12 Operating the movable part of the bed – remote control unit

 **Check that the bed is in the lowest position when the patient is sleeping and/or not being monitored.**

The movable sections of the bed are powered by strong electrical actuators controlled by the remote control unit.

To prevent the remote control unit from being activated inadvertently by the patient or a visitor, put it in a safe place (for instance, attached to the exterior of the side rail).

Do not allow children to play with the remote control.

When operating the bed, ensure that no person, animal or object is at risk of being trapped. Check that there is nothing under the bed.

Ensure that electrical cables are not trapped or positioned too close to the movable section of the bed (head or foot actuators). Similarly, check that nothing near the cables could damage them.

1.12.1. Electrical system

If any doubts about whether electrical components are operating correctly, remove the power plug from the wall socket to eliminate any risk of electric shock and contact the NIPI-M dealer.

 **If there is a continuous signal from the control box, see section 2.5.2. Integrated locking system.**

 **Make sure the cables are routed appropriately to avoid tangling or strangulation. See paragraph 3.7. Electrical equipment.**

Never open the casing of the electrical components.

1.12.2 Load on the bed

Do not exceed the maximum authorized load (including the weight of accessories).

The bed is design for the patient only. No one should sit on the bed or lean on the edges of the bed if part of the platform is inclined or raised. Incorrect use could damage the actuators or the movable structure.

The patient should avoid placing all of their body weight on the backrest or the leg rest in the inclined position, as this could damage the bed.

Do not apply a load of over 60 kg on the backrest or 40 kg on the leg rest.

1.12.3. The trapeze bar

The maximum permissible downwards load is 75 kg.

The trapeze bar is not designed to lift people, but to help transition from lying down to sitting position or to change position.

1.12.4. Braking system

The four castors of the bed are equipped with parking brakes.

Always keep the brakes applied except when the bed is moved.

Apply the brakes immediately after any move.

Never sit on the bed when the brakes are not applied.

1.12.5. Use of original parts

Use only original NIPI-M spare parts for repairs and maintenance. The warranty is no longer valid if parts others than those recommended by NIPI-M are used.

Use of other parts can put the patient in danger.

 **The bed must only be used with accessories supplied by NIPI-M, such as the side rails, trapeze bar and bed extensions.**

1.12.6. Complaints

Please inform the NIPI-M dealer about any incident related to the use of the bed.

2. OPERATING THE BED

Carefully read the safety information in the previous section before operating the bed.

2.1. Check the following points regularly

At least once a day or before the bed is used:

- Mattress correctly placed between the mattress holders
- Side rails free from any visible signs of damage or deformation
- Side rails correctly attached (check by applying pressure)
- Cables free of any visible damage
- Bed connected to the power supply

At least once a week:

Are the distances between the wooden parts of the side rails correct?

Are all parts free of visible damage, cracks or deformations?

Are all fastenings (including wing nuts) correctly tightened?

 **If any bed component becomes detached, loose or visibly damaged, contact a specialized dealer or healthcare professional.**

2.2. Locking and unlocking the castors



Unlocked



Locked

- To apply the brakes: push down the brake pedal.
- Lift the pedal to release the brake.

 **Do not forget to lock the castors by engaging the brakes prior to use.**

2.3. Moving the bed on wheels

People not needed while moving the bed should stay away.

Before moving the bed, make sure the platform is in the lowest position, the side rails are raised, the power plug is disconnected, the power cord is secured around its holder, and remote control are hooked to the bed head or side rail.



Cable holder



Remote control hook

- Before using the bed, and each time it is moved or adjusted, check that no cables hang down to the floor or risk becoming trapped.
- Do not roll over the cables.
- Do not forget to lock the castors by engaging the brakes prior to using the bed.
- Before and after every procedure, check that all the wing screws of the platform are properly tightened.

24. Operating the side rails

- When raising or lowering the side rails, make sure that no part of the patient's body becomes trapped. This instruction applies particularly to the space at the head of the bed.
- When operating the side rails, hold them firmly to stop them falling too quickly. This could hurt the patient and/or damage the side rails.
- There is a risk of getting caught when assembling or operating the side rails.

24.1. Wooden side rails



- To lock a side rail in the raised position:

Pull the rail upwards until it clicks.

- To lower a side rail:

Starting at one end of the rail, raise it, press the release button and lower the rail. Do the same at the other end and gently lower the rail to the bottom.

For Vereya ECO:

- To lower a side rail:

Starting at one end of the rail, raise it, pull the fixator and lower the rail. Do the same at the other end and gently lower the rail to the bottom.

Unlocking button/ fixator

- In the locked position, the distance between the side rails and the head board must be 2.5 to 6 centimeters.

25. Operating the moving parts of the bed

The movable sections of the bed are powered by strong electrical actuators activated by the remote control unit.

The bed's electrical system must not be operated continuously for more than two minutes. The remote control must not be activated more than five times per minute. Do not operate several buttons at the same time.

- Usage cycle: 15% - continuous activation for 2 minutes followed by a 12-minute break - no more than 5 cycles per minute.
- When adjusting the head or foot of the bed, check that the patient's armor legs are not resting on the edge of the bed to avoid injury.
- The remote control must be stored in a safe location to avoid unintentional use.

Note: This bed has the possibility of tilting the plane of the mattress, positive and negative..

2.5.1. Remote control unit

- Remote control functions:



1	Raise the backrest	2	Lower the backrest
3	Raise the leg rest	4	Lower the leg rest
5	Raise backrest and leg rest	6	Lower backrest and leg rest
7	Raise the bed	8	Lower the bed
9	Reverse Trendelenburg position	10	Trendelenburg position

2.5.2. Integrated locking system

There is a lock on the rear of the remote control. This lock is operated by a removable key.

When the bed is delivered, the key is attached to the remote control, but it can easily be removed.

We recommend having a second key available to ensure that the remote control can be operated if the first key is lost.



Dark gray locking key

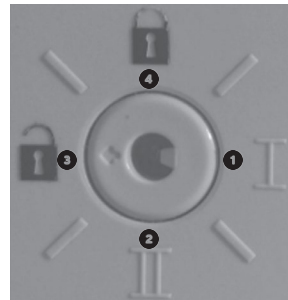

Locking functions

Lock position:	
3	Full access to all functions.
4	All functions locked.
1 and 2	Test positions for safety checks.

(See the maintenance section of this manual)

Position:	
	All functions locked. Note: in this position, there is a beeping sound whenever a button is pressed. This feature is designed on purpose.
	Full access to all functions. In this position, a continuous beeping sound from the control box means that the bed needs to be serviced.
	Maintenance. Note: in this position, there is a beeping sound whenever a button is pressed. This is a designed feature.

! Remove the locking key to prevent any unauthorized changes.

! Always deactivate the bed functions when in doubt about the patient's ability to operate the bed safely due to their physical or mental condition.

2.6. Lower leg rest adjustment

When the remote control is activated, the leg rest automatically moves to the semi-seated position, with the knees bent.

The leg section can be raised manually by pulling it upwards to the desired position. To lower it, pull it upwards as far as it will go and then push it back down to the lowered position.

When the the entire leg rest is lowered electrically, it will automatically return to the semi-seated position the next time it is raised.

2.7. Emergency flat position (bringing the bed into flat position)

If the main power supply fails, the backrest can still be brought to the horizontal position.

! Remove the plug from the power socket before lowering the backrest.

- Procedure 1: using the backup battery

This works only if the backup battery is fully charged, the system is not locked and no electrical components are faulty.

Press the horizontal button on the remote control. The bed will lower slowly.

This function should only be used in case of emergency. Afterwards the backup battery must be renewed immediately.

- Procedure 2: disconnecting the actuator from the platform

(This procedure should be used if the backrest actuator fails or the battery is empty.)

! At least two people are required to perform this procedure.

- One assistant holds the backrest slightly raised.
- While supporting the backrest actuator, the other assistant opens the safety spring retainer of the pin and pulls out the pin.
- Let the actuator fall back.
- Both assistants can then lower the backrest to the horizontal position.

! Slowly lower the backrest until it is completely flat.

Note: after troubleshooting the failure, the actuator can be reattached to the platform. Lower the actuator using the remote control and reattach it to the platform with the pin.



Quick-release pin to fix the actuator

! Check that the locking clip of the quick release pin is in the locking position.

2.8. Troubleshooting procedure: what to do if the bed actuators malfunction

A. Start by checking:

- Is the power plug connected and the power supply voltage active?
- Is the locking key in the unlocked position?
- Are all the components correctly connected to each other?

B. Have the actuators stopped due to overload or operating too long without a pause?

- Unload the bed and do not operate it for 14 minutes. Check if the electrical actuators work again.

C. If the problem persists:

- Disconnect the power plug from the socket. Contact the specialized dealer who supplied the care bed and describe the problems encountered.

! Do not use the bed if electrical components are defective. Never open any electrical components.

3. ASSEMBLING THE BED

Only trained personnel must assemble or disassemble the bed.

First read and understand the safety instructions in this manual.

Do not connect the power supply before the final inspection of the assembly.

Do not press any buttons on the remote control, as this could activate certain electrical actuators via the backup battery.

Handle the parts carefully to avoid damaging electrical or other components.

! After assembling the bed, and before using it, follow the inspection instructions.

3.1. Unpack and check all the parts

Refer to the drawings at the end of the manual.

3.2. Position the platform actuators

For transport, the platform actuators may be attached below the support and fastened with cable ties.

If this is the case, reposition the actuators after unpacking the platform.

Cut the ties, remove the quick-release pin and raise the actuator until the holes match. Reposition the quick-release pin and fold the locking clips back.



Back rest



Leg rest

3.3. If a bed extension is used

If a 10 cm extension is necessary (mattress dimensions: 80 x 210 / 90 x 210 cm), slide it into the frame at the **leg rest end**. Fasten the wing screws tightly.

If a second 10 cm extension is necessary (mattress dimensions: 80 x 220 / 90 x 220 cm), slide it into the frame at the **backrest end**. Fasten the wing screws tightly.

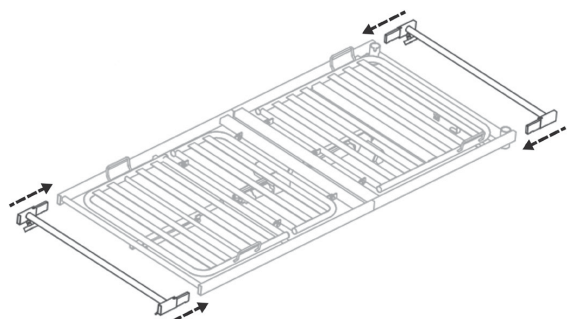

Assembling bed extensions

3.4. Assembling the bed parts

There are several ways to assemble the bed, depending on the experience of the person performing the task, the floor surface and the amount of physical strength required. The following method is the easiest in terms of physical strength.

- Place the head end of the bed against a wall and block the two castors by applying the brakes.
- Slide the platform backrest and head end together.
- Fasten the wing screws tightly.
- Position the foot end of the bed against a wall and block the two castors by applying the brakes.

- E. Slide the platform leg rest and foot end together.
- F. Fasten the wing screws tightly.
- G. Release the brakes and slide the two parts of the platform together.
- H. Push the two parts together completely and tighten the wing screws firmly.
- I. Remove the cable ties.

 **Check that all the screws are tight!**

Before using the bed, take care that all the transport security measures (straps and packing) are loosened or removed. The mattress should be positioned correctly between the mattress holders

3.5. Assembling the trapeze bar (option)

 The maximum load on the trapeze bar is 75 kg.

 If the trapeze bar is used when the triangle has been turned away from the bed platform, the bed may tip when weight is applied.



- Position the trapeze bar so that the triangular handle is above the bed.
- Insert the lower end of the trapeze bar in the support located by one of the corners of the bed head.
- Take care to insert the guide pin into the notch in the support.
- Slide the strap of the triangular handle over the upper section of the trapeze bar, between the two small vertical pins.
- The length of the triangular handle strap can be adjusted with the buckle. Choose a length enabling the patient to reach it easily from lying position. Check that the belt is fixed safely.

3.6. Assembling the wood rails (option)



Sliding channel and low position button

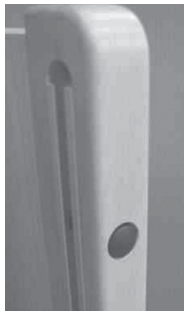

Side rail top locking button/ fixator



Slider. triangular end upwards

The procedure is the same for both sides of the bed.

- A. At one side of the head end of the bed, remove the bolt and insert a side rail's sliders into the sliding channels, with the triangular end pointing upwards.
- B. Slide the slider upwards until it clicks into place. Push the low position button and pull the slider further upwards. Screw the bolt back into place.
- C. Place two side rails side by side and insert the four pins of the already inserted slider into the ends of the side rails. Check that the rounded edges of the wooden rail are pointing upwards.
- D. Go to the foot end, remove the bolt, insert the pins of one of the sliders into the side rails (triangular end upwards) and slide it into the sliding channel until it clicks into position. Push the button and pull the slider further upwards. Screw the bolt back into place. The side rails can be pulled upwards until they lock.

 **Make sure the side rails are assembled so that the distance to the board is between 2.5 and 6 centimeters.**

3.7. Electrical equipment

 **DO NOT CONNECT to the mains power supply before the final inspection of the assembly. See the "Final inspection of the assembly" section.**

 **Inappropriate handling of the cables, incorrect connections and using unauthorized equipment could cause product malfunctions, electric shocks and electrocution.**

3.7.1 Description

The bed is fitted with the most recent ILCON Switched-Mode Power Supply (SMPS).

The low-voltage current is routed to the SMPS control box by a cable with connectors.

This control box is located under the platform. It is attached to the backrest actuator and its function is to protect the circuits relaying the remote control actions to the actuators.

The actuators and the remote control are connected to the ilcoPower control box.

All low-voltage connectors are fitted with a flexible sealing ring (Oring), giving protection against humidity.

Note: some models incorporate a 9V backup battery located inside the control box under a gray lid.



3.7.2 Electrical connection

 **Follow the sequence as described. DO NOT CONNECT to the mains power supply before the final inspection of the assembly. See the "Final inspection of the assembly" section.**

 **Check that the Oring is present on each low-voltage plug and not damaged. Insert each plug into the corresponding socket firmly and fully.**

 **During bed adjustments, check that cables do not get caught or pulled too tight and do not dangle or rub on the floor.**

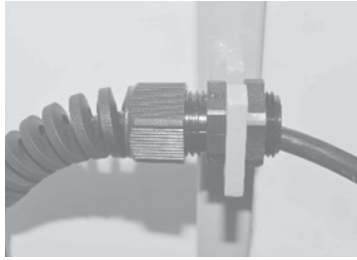

Strain relief bushing



! Carefully align the plug before inserting it to avoid bending the pins.

The remote control is factory-assembled and the cable is routed via the strain relief system on the outside of the ilcoPower control box.

If this is not the case (when replacing a part, for example), route the cable as shown and insert it into the connector.

3.8. Final inspection of the assembly

After all tasks are complete, and before using the bed, a final check must be carried out.

- Before connecting to the mains power:

Point to check	Specific check
Cables and SMPS	- Coiled extension not pulled too tight. - Not trapped in moving parts - Not dangling or rubbing on the floor.
Wall socket	- Compliant with the electrical specification of the SMPS.
Wing screws	- All the screws are tight.
Side rail	- Moves up and down when the lock is in open position. - Secured lock in raised position.

- Finally, connect to the mains power and perform the final checks as follows:

Point to check	Specific check
Motion functions	All parts move smoothly.
Remote control actions	Match the symbols on the remote control, including the locking function. Carry out the following safety checks: position 1 and 2 of the locking key.
Final position of the bed	The moving parts of the bed move freely and are away from any obstacles that could injure the patient.

A cable links the control box to the low-voltage socket of the SMPS. The cable is fixed to the bed frame with a strain relief bushing.

Check that this bushing is firmly fixed to the frame.

Run the cable between the two cross tubes at the head of the bed.

Connect the actuators to the control box.

During the connection phase, the actuators may move slowly if any of the remote control buttons are pressed inadvertently, activating the backup battery.

The backup battery is sometimes included in the ilcoPower controlbox.

First connect the actuators, and then connect the remote control.

Connection diagram

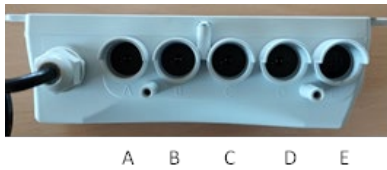

Ref.	Action
A	Variable height adjustment
B	Variable height adjustment
C	Leg rest
D	Backrest Factory connected.
E	Remote control unit. Factory connected.

Connecting the actuators

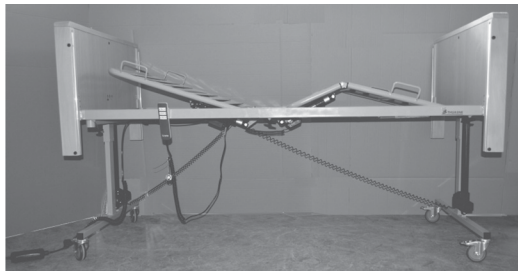

The two coiled cables of the bed's high/low motors should hang freely when connected to the ilcoPower control box.

Connecting the remote control



3.9. Moving the bed on wheels

See section 2.3

3.10. Disassembling the bed

! When disassembling and transporting the bed, the moving parts must be secured (e.g. with straps). Any unexpected movement could injure operators and/or damage the bed.

Lower the platform to the horizontal position.

- Remove the plug from the power socket.
- Wind the power cable around the cable support.
- Unplug the electrical connections of the high/low actuators and the leg rest actuator.
- The remote control unit and the backrest actuator can stay connected.
- Disassemble the bed by following the assembly instructions in reverse order.
- Check that no electrical cables or connections are trapped.

3.11. Storage and transport kit

When it is not in use, the bed can be easily transported and stored using the NIPI-M transport kit.

! Ensure that the floor is flat, stable and horizontal when assembling, transporting, and storing the bed on the transport kit

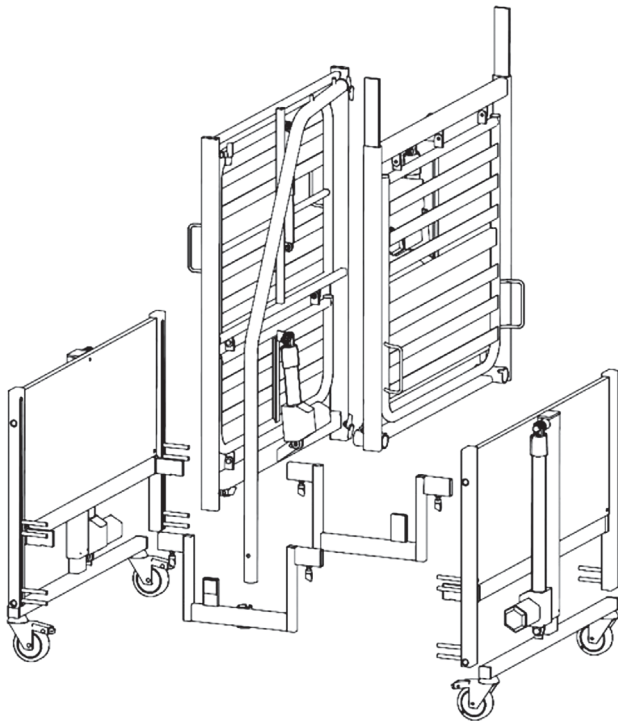

- Disassemble the bed.
- Attach the head and foot of the bed to either side of the transport kit and tighten the wing screws. The transport kit is now resting on its castors.
- Place both sections of the bed platform on the vertical studs of the transport kit.

3.12. Packaging material disposal

Depending on the type of delivery, the packaging may consist of paper, cardboard, PE film, polystyrene, and wood. Refer to the local waste disposal requirements.

3.13. Disposal of components at the end of the bed's useful life

The BUL G1 bed consists of a welded, painted steel frame, electrical actuators and wooden fittings. Do not dispose of electrical components with household waste.

4. TECHNICAL SPECIFICATIONS

4.1. Technical data

SMPS adaptor
 Power supply: 100-240 V~ 50/60 Hz.
 Standby energy consumption according to Energy Star guidelines < 0.5 W.
 Max. use cycle: 15% (max. 2 minutes continuous activation followed by 12 minutes break).

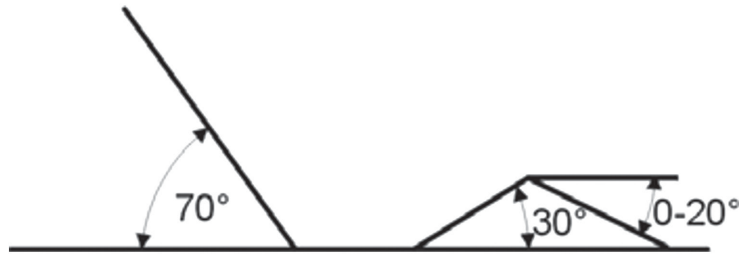

Fig. 2: Angles of the platform

Platform	80 x 200 / 90 x 200 cm
Lowest platform height	40 cm
Highest platform height	80 cm
Overall dimensions	105 x 214 cm
Weight (unloaded)	Bed: 84 kg Trapeze bar: 6.4 kg Side rails: 9 kg Accessories: 0.25 kg
Maximum permitted load on the bed	Max. weight of the user: 135 kg Mattress: 20 kg Accessories: 15 kg Total max. bed load: 170 kg
Maximum load on the trapeze bar	75 kg
Maximum load on the side rails	75 kg (per side)
Heaviest sections of the bed	Weight: 20 kg
Dimensions	81.5 x 95 / 105 x 7.5 cm (Vereya) 84.5 x 95 / 105 x 9 cm (Vereya plus) 85.3 x 100 / 110 x 9.5 cm (Vereya ECO)
Back section	70° (see figure 2)
Leg section	0-30° thigh section (see figure 2) 0-20° lower leg section: 5 height settings (see figure 2)
Electrical category	Class II
Noise level	Less than 65 dB
Maximum permitted mattress height	12 to 16 cm (Wood side rails)
Storage conditions	Temperature: -10°C to +45°C Humidity: 40% to 70%

4.2. Mattress characteristics

See paragraph 6.3. Mattress specifications.

5. MAINTENANCE INSTRUCTIONS

5.1. Inspection and maintenance

To avoid any accidents and increase the lifespan of the NIPI-M bed, a thorough inspection procedure should be conducted at least once a year, or each time the bed is reinstalled (consult local legislation and regulations, which may impose more inspections).

Follow the protocol for this inspection.

The verification points described should only be carried out by, or under the supervision of, specialised personnel with relevant training.

5.2. Measurement of the general electrical system

This must at least include an examination of electric current leakage from the transformer and a measurement of the insulation resistance. This verification procedure must be carried out by a qualified electrician or a trained electromechanical engineer using appropriate measurement and test equipment and methods.

5.3. Backup battery (if available)

If the mains power fails, the bed can be brought to its lowest position and the platform can be set to horizontal. This makes it possible for the bed to function without mains power, but the battery is exhausted very quickly.

When the backup battery is exhausted, it must be replaced by a new 9V 6LR61 (alkaline type) battery. Proceed as described below.

Open the battery case located by the backrest actuator. Be careful to avoid damaging the seal. Pull the old battery out and remove the connector. To fit the new battery, follow the instructions in reverse order



The backup battery should be replaced at least every two years and after each emergency use.

5.4. Cleaning and disinfecting

Never use a high pressure cleaner to clean this bed. Do not splash the bed with water.

Before cleaning and disinfecting the bed, check that all cables and connections are intact to prevent liquid entering. Damaged parts must be replaced.



Check that the power plug is disconnected. Protect the ilcoPower system's electrical contacts from moisture.

All the actuators and the remote control unit are connected to prevent humidity entering the plugs and sockets in order to avoid malfunctions or short circuits. Each socket must be fitted with an intact sealing ring.

Although the electrical components are protected against splashing, clean them only with a damp cloth and, if necessary, a mild nonabrasive detergent.

Make sure all the parts of the bed are perfectly dry before using the bed again.

The metal parts of the bed can be cleaned by hand with water and soap (such as a mild detergent).

Wooden parts should be wiped with a damp cloth and dried immediately.

Use a suitable product to maintain the wood.

In institutions, follow the recommendations of the hygiene manager.

Disinfection:

Spray the bed lightly with a mild commercial disinfectant.

Do not use products with a high content of alcohol, ether, ketenes, esters, concentrated acids or aromatic or chlorinated hydrocarbons.

The wooden parts should be cleaned with a fast-acting disinfectant. Spray the wood and wipe it dry immediately.

After cleaning and disinfection, apply a special wood preservative.

6. APPENDIX

6.1 Servicing schedule for the NIPI-M BUL G1 bed

Model:	Serial number:	Manufacture year:
---------------	-----------------------	--------------------------

At least once a year after installation or reinstallation (see local regulations, which may impose more inspections).

Maintenance reason:

<input type="checkbox"/> Annual	<input type="checkbox"/> Following repair	<input type="checkbox"/> Following reinstallation
---------------------------------	---	---

	OK	Defect
Evaluation of the electrical system		
This verification procedure must be carried out by a qualified electrician or a trained electromechanical engineer, using appropriate equipment, and measurement and test methods.		
Current leakage from the transformer ≤ 0.100 mA (EN 606011)		
Insulation resistance ≥ 7 MOhm (see VDE 0751 standard)		
Note: the system is considered faulty if the values deviate by more than 50% from those measured the first/previous time.		
General condition		
Do all moving parts (including side rails) move easily? Are any parts rusty?		
Do any parts hang loosely or rattle when the bed is moved?		
Are there any scraping or grinding noises when the bed is moved?		
Are the platform, head and foot end of the bed, backrest, seat, leg rest, support or castors bent/deformed?		
Are there any visible cracks or signs of wear on any component?		
Are the actuator supports intact and free of visible signs of deterioration?		
Have the side rails been altered? Have they deteriorated or lost their shape?		
Do the castors turn easily and are all the brakes working properly?		
Is the ilcoPower control box housing firmly attached to the backrest actuator?		
Are all the actuator housings and covers intact, firmly attached and free of signs of wear?		
Are the socket and the inner compartment (cover plate at the top of the bed head) free from signs of corrosion and wear? (Only on certain models)		
Are the trapeze bar and its support free from signs of corrosion, wear and cracks?		
Are the triangular handle, strap and buckle intact? Are they free from signs of wear, discoloration, and damage?		
Do the side rails click firmly into the locking position when raised and can they only be released if lifted up a little?		
Do the side rails withstand a vertical load of 75 kg (in the raised position)?		
Is the distance between the two boards (wood side rails) still the same and less than 110 mm?		
Is the gap between the wooden side rails and the head/foot of the bed less than 8 mm?		
Check if the individual platforms can be adjusted in all directions and positions (in accordance with the technical specifications).		
Functional check		
Check that the actuators move the full distance until they stop and check this distance for each actuator (variable height 400 to 800 mm, 110 mm for the backrest, 39 mm for the leg rest). Do they comply?		
Are the noise level and speed in accordance with the technical specifications? Do all the actuators stop when they have reached the end of their stroke?		

	OK	Defect
Is the maximum current value of the actuators when not assembled less than 1 A?		
Compare the speed of the actuators for adjusting the height: is the difference in the time taken to complete their run less than 3 seconds?		
Does the backup battery have enough energy? If in doubt, replace it.		
Power cable and SMPS adaptor		
Is the SMPS adaptor casing in good condition, with no cracks, and is the outer insulation of the cables intact?		
Is the power cable intact, including its outer insulation?		
Is the strain relief system on the power cable and the plug-in good condition, and it is working perfectly?		
All cables		
Are all the plugs fitted with Oring seals in good condition?		
Are all the plugs intact (no imperfections, crushing, cracks etc.)? Are the coiled sections free from stretching and the insulation undamaged?		
Check that the positioning and attachment of the cables is consistent with the cable installation technique.		
Remote control unit and locking system		
Do all the buttons function properly without sticking?		
Does the system lock when placed in the locked position and in position I and II?		
Is the housing undamaged, and is the strain relief system intact?		
Is the cable of the remote control routed via the strain relief system on the transformer?		
No beep signal from the control unit		
Documentation		
Is the user manual present?		
Are all the adhesive labels firmly attached and readable?		
In addition, the following actions must be recorded for safety reasons:		Date:
Every five years: change the trapeze bar		
Every two years: change the backup battery		
Every three years: change the triangular handle and the strap		
Description of defects, comments, actions:		

Checked by:	Location:	Date:
--------------------	------------------	--------------

62.1. Complete bed

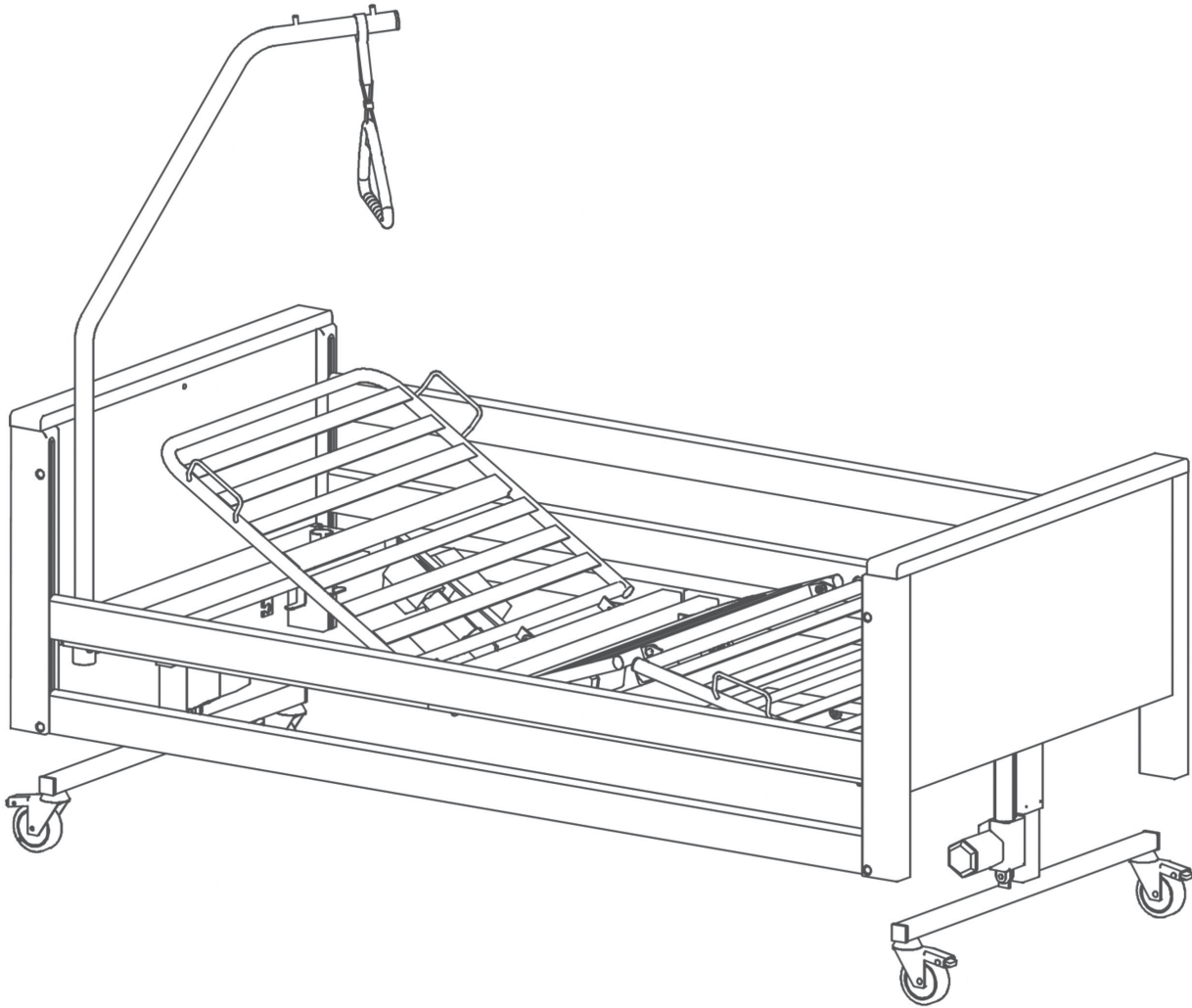

Vereya plus with wooden side rail

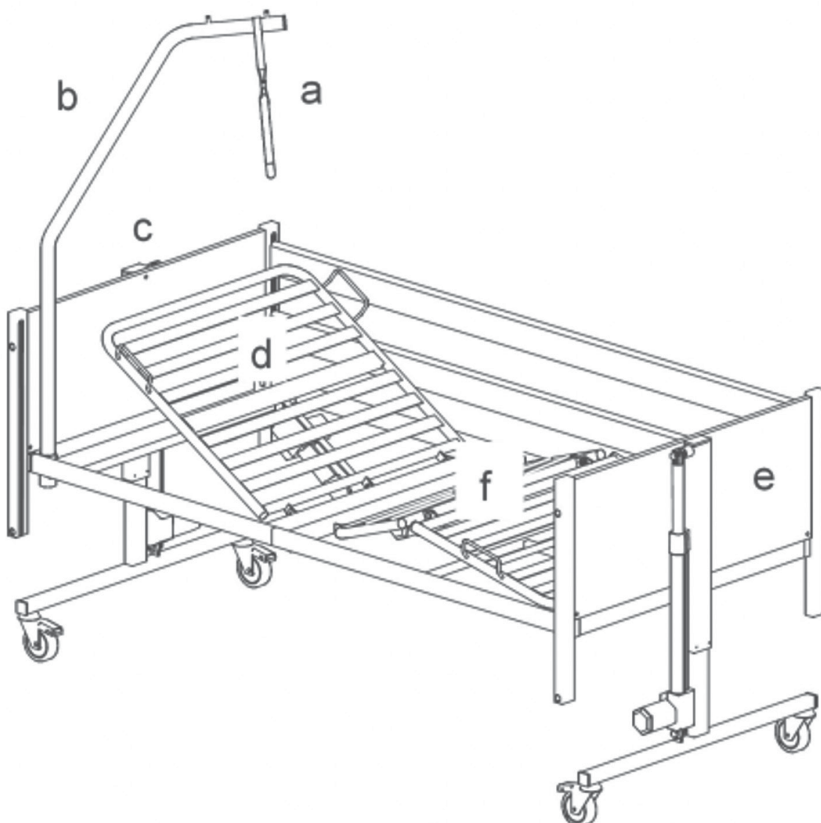

a	Triangular handle and strap
b	Trapeze bar
c	Head of the bed
d	Backrest
e	Foot of the bed
f	Leg rest

Vereya with wooden side rail

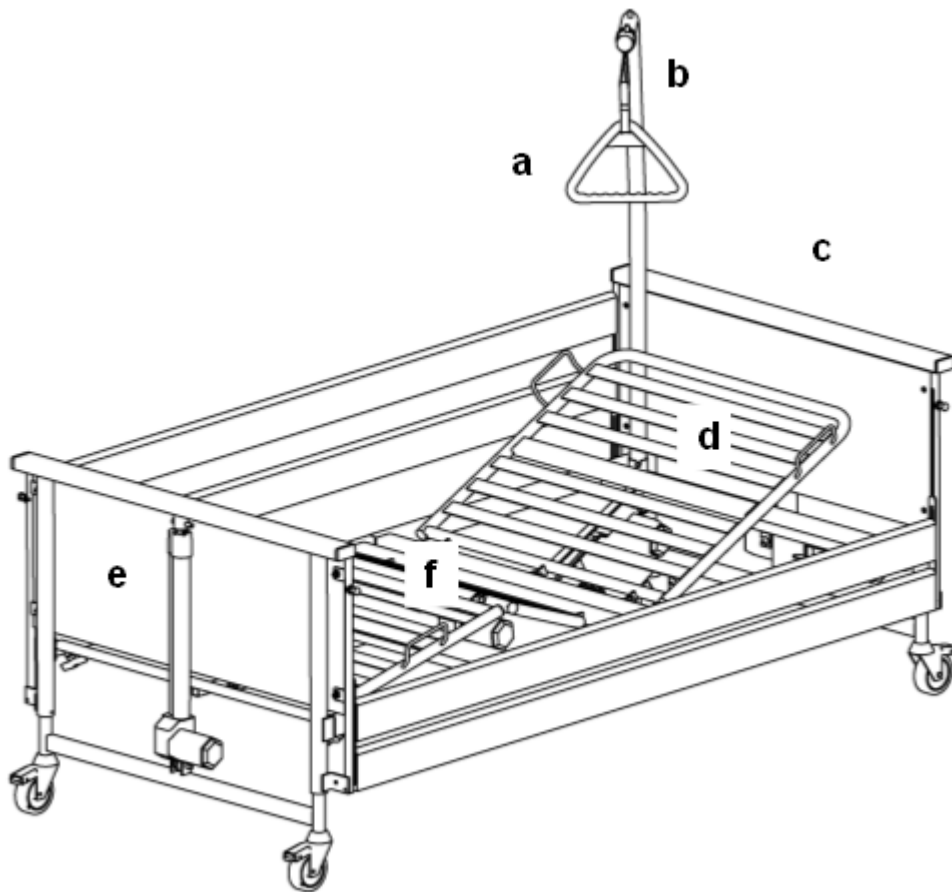

a	Triangular handle and strap
b	Trapeze bar
c	Head of the bed Vereya ECO
d	Backrest
e	Foot of the bed Vereya ECO
f	Leg rest

Vereya ECO with wooden side rail

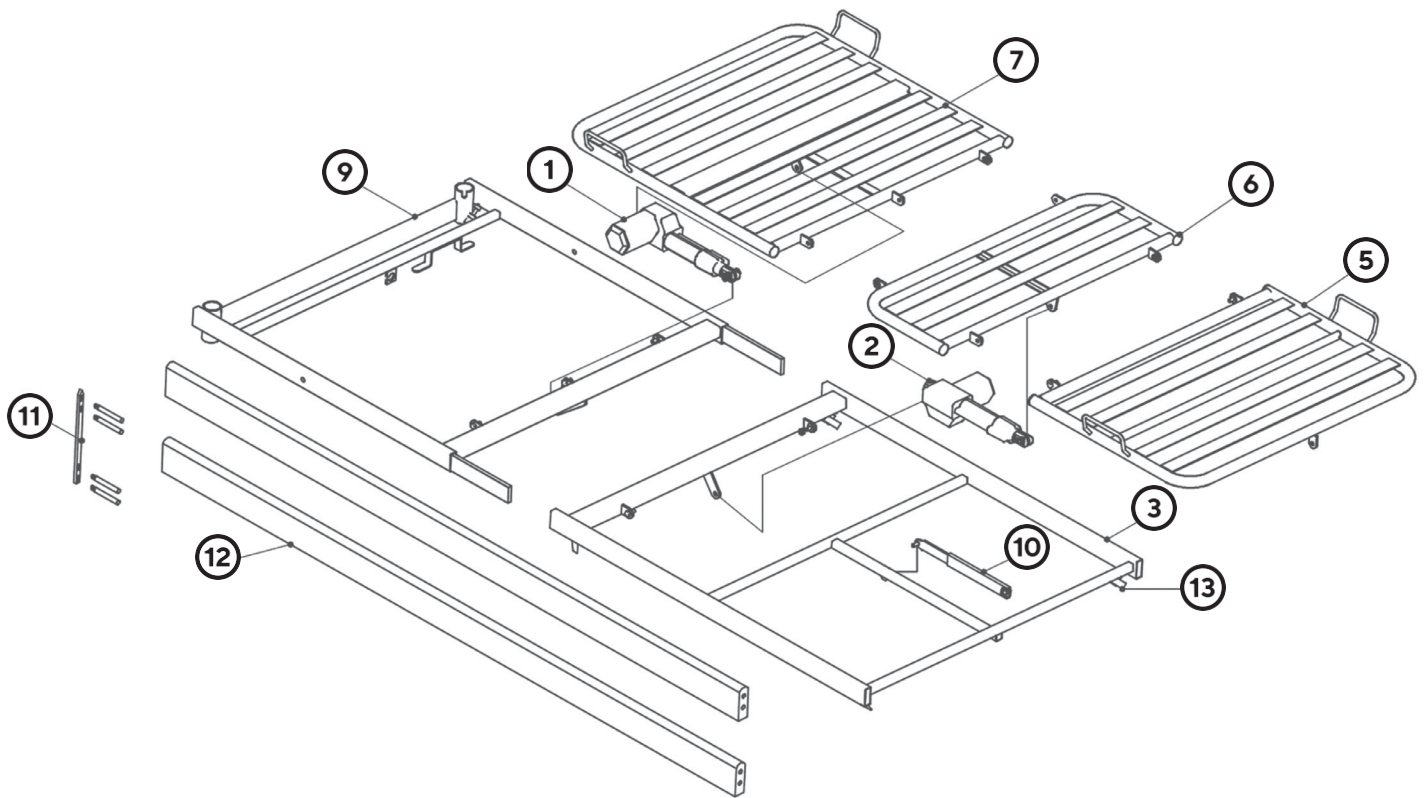

Ref.	Description	NIPI-M ref.
1	Backrest actuator	See the electrical system below
N/A	Quick-release pin for removing the backrest actuator quickly	BGV8300800
2	Leg rest actuator	See the electrical system below
9+7	Frame for backrest 80 cm, complete	BGV8400682-80
	Frame for backrest 90 cm, complete	BGV8400682
3+5+6	Frame for leg rest 80 cm, complete	BGV8400681-80
	Frame for leg rest 90 cm, complete	BGV8400681
10	Support for Fowler's position, including screws and nuts	BGV8400350
11	Profiled sliders for side rails (set of 4)	BGV215010705
12	Wood side rails (pair) 198 cm (for Vereya ECO)	BGV214927220
	Wood side rails (pair) 200 cm	BGV214927222
	Wood side rails (pair) 208 cm (for Vereya ECO)	BGV214927221
	Wood side rails (pair) 210 cm	BGV214927232
	Wood side rails (pair) 220 cm	BGV214927242
N/A	Wing screw FOR BED HEAD 100 mm	BGV8200356
13	Wing screws 30 mm	BGV8200355
N/A	Bed extension 10 cm	BGV215010022

6.2.3. BUL G1 head and foot

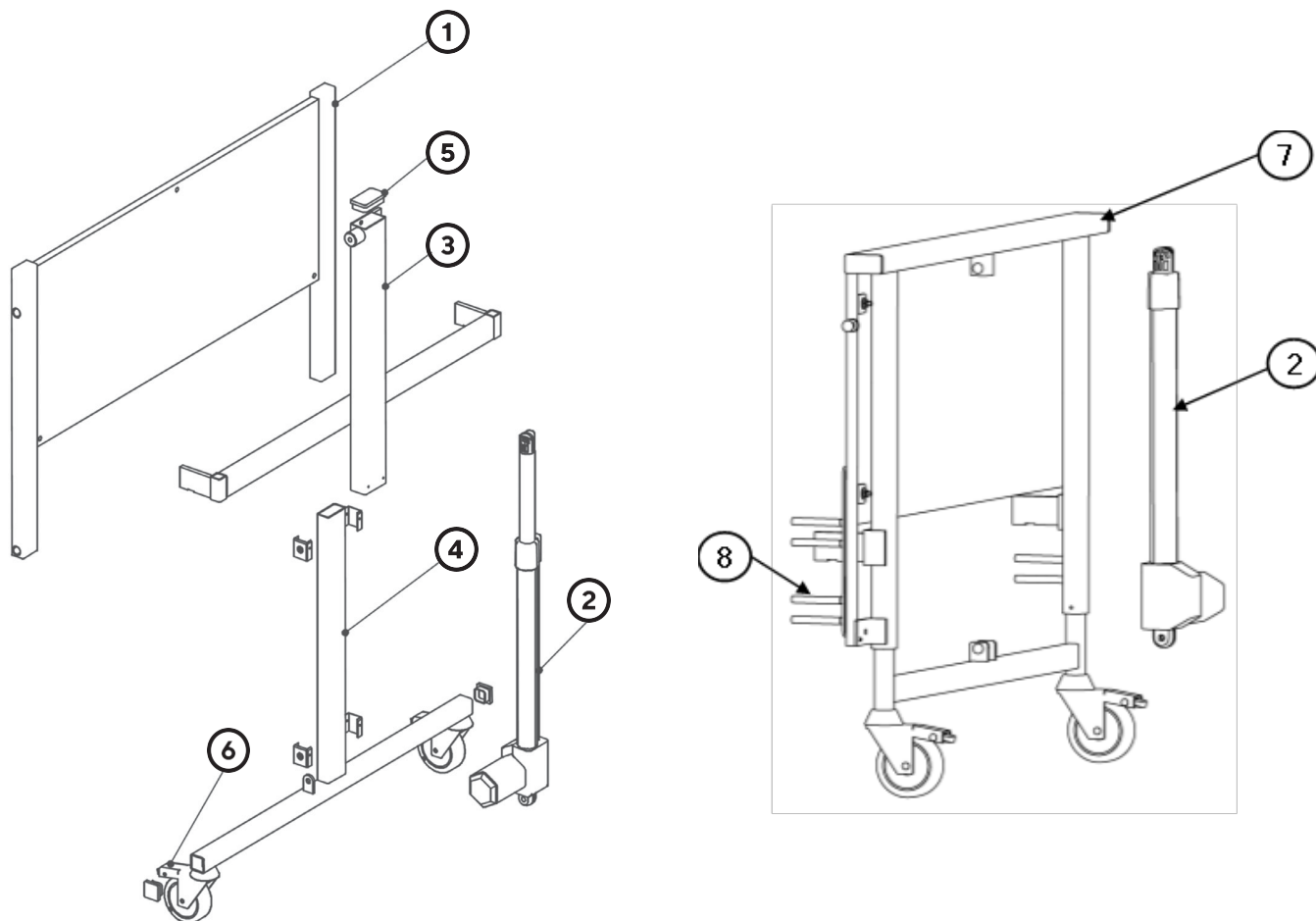

Ref.	Description	Model	NIPI-M ref.
1	Wooden panel - bed head/foot 80 cm	Vereya	BGV8400620-80
	Wooden panel - bed head/foot 90 cm	Vereya	BGV8400620
N/A	Wooden panel - bed head/foot 80 cm	Vereya plus	BGV8400660-80
	Wooden panel - bed head/foot 90 cm	Vereya plus	BGV8400660
2	Actuator - bed head/foot	All	See the electrical system below
3 + 4	Top/bottom frame - BUL G1 bed head/foot 80 cm	Vereya and Vereya plus	BGV8400411-80
	Top/bottom frame - BUL G1 bed head/foot 90 cm	Vereya and Vereya plus	BGV8400411
5	Column cover 70 x 40 mm	Vereya	BGV8300820
6	Swivel fork with wheel (100 mm)	All	BGV8400500
7	Head and foot end 80 cm	Vereya ECO	BGV8400601-80
	Head and foot end 90 cm	Vereya ECO	BGV8400601
8	Profiled sliders for side rails (set of 4)	All	BGV215010705
N/A	Transport kit	All	Check with customer services.
N/A	Trapeze bar including triangular handle and strap	All	BGV214910110
N/A	Triangle grip and strap	All	BGV8200901
N/A	User manual	All	Check with customer services.

RAL 1019 glossy paint spray can: not supplied by NIPI-M (available commercially)

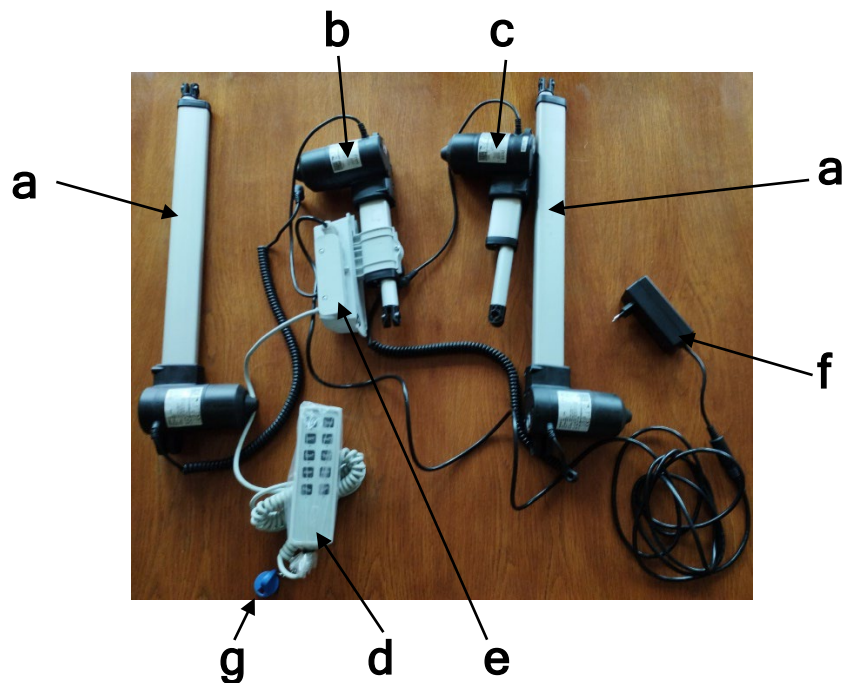

	Designation	NIPI-M ref.	Ref./Designation on label
a	High/low actuator	BGV8300120	411145 --Ilco Drive IZ -600-400-
b	Backrest actuator	BGV8300210	411141 --Ilco Drive IZ -305-110-
c	Leg rest actuator	BGV8300231	411144 --Ilco Drive IZ -308-39-
d	Remote control	BGV8300286	410615 --Ilco Control IP
e	Relay box	BGV8300224	410881- --Ilco Power 4
f	SMPS unit	BGV8300221	410527 - SMPS adaptor--Euro plug
g	Locking key	Check with customerservices	

6.3. Mattress specifications

Mattress height:

12 to 16 cm (Wooden side rails)

Mattress dimensions	NIPI-M ref.
No extension 80 x 200 / 90 x 200 cm	Check with customer services
One extension 80 x 210 / 90 x 210 cm	Check with customer services
Two extensions 80 x 220 / 90 x 220 cm	Check with customer services



If a different/special mattress is used, the risks of this combination must be assessed by the user or the person prescribing the mattress.

6.4. Warranty

The warranty only covers manufacturing defects and/or materials. It applies to the following items:

- Bed frame: 2 years
- Electrical components: 2 years (excluding the backup battery)





The warranty begins on the day on which the bed is purchased. If a component proves to be defective during the validity period above, NIPI-M will replace or repair the component unless the defect is due to incorrect handling.

Products that have been used incorrectly or negligently, poorly serviced or stored under inadequate conditions are not covered by the warranty. Damage due to overloading or malicious acts is also not covered.

Any unauthorized interference with the electrical components or operation on the electrical system will invalidate the warranty.

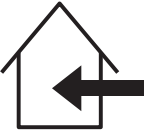
Unless expressly authorized by NIPI-M, worn parts may only be repaired or replaced by a qualified technician.

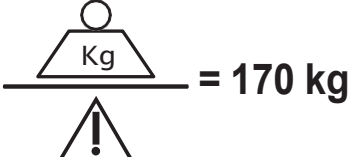
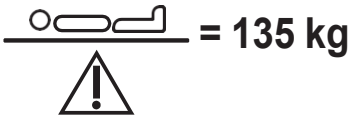
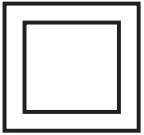
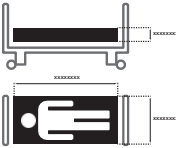
The bed is supplied with adhesive labels specifying serial numbers. Please quote these serial numbers in case of a complaint.

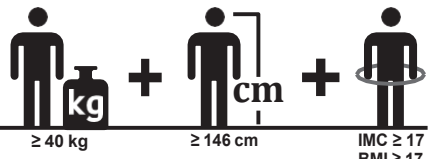
	<p>Consult the user manual.</p>
	<p>Only use the bed indoors.</p>
<p>IPX4</p>	<p>The product is protected against water splashes.</p>
	<p>The protection class, type B in this case, which means that the transformer is equipped with a primary cut-off mechanism.</p>
	<p>Maximum authorized load: 170 kg (including the mattress, accessories and the user's weight).</p>
	<p>Maximum user weight: 135 kg</p>
	<p>Class II insulation.</p>
	<p>Characteristics of the mattress to be used. See paragraph 6.3. Mattress specifications.</p>
	<p>Warning: Using incompatible side rails can cause risks. Ensure that the side rails described in this user manual are used.</p>
	<p>The BUL G1 bed is designed for an adult whose:</p> <ul style="list-style-type: none"> - weight is 40 kg or over, - height is 1.46 m or over, and with a Body Mass Index of 17 or over.

www.nipim.org

