

Nursing care beds

.bock^{///}

- belluno
- livorno low
- combiflex / combiflex.fc
- pratico 25/80
- pratico economic



Dear valued customer,

with your decision to purchase a nursing care bed from Hermann Bock GmbH, you are receiving a long-lasting care product with superior functionality at the highest safety level. Our electrically operated nursing care beds guarantee optimal lying comfort and allow professional care at the same time. This product was designed with a focus on the elderly, whose confidence must be reinforced and whose life needs protection. With this health care product, we meet these requirements.

We urge you to prevent potential malfunctions and the risk of accidents by complying strictly with the safety and operating instructions and by carrying out the necessary maintenance.



Klaus Bock



Dr. Stefan Kettelhoit

Table of contents

1	Preface and general instructions	4
1.1	Intended purpose	4
1.2	Definition of person groups	5
1.3	Safety instructions	6
1.4	Service life / warranty	7
1.5	Requirements for the installation location	7
1.6	Type plate	8
2	General description of the functions	10
3	Electric parts	17
3.1	The drive unit	17
3.2	Caution: Electric drive	18
3.3	Drives	19
3.4	The external switching power supply SMPS from Limoss	19
3.5	The mains isolation from ILCON	20
3.6	The ICS drive system	21
3.7	The system moves without adequate permission	21
3.8	Resetting the position after triggering the MSE	21
3.9	The hand control	21
4	Assembly and operation	24
4.1	Technical data	24
4.2	belluno	25
4.3	livorno low	28
4.4	combiflex / combiflex.fc	31
4.5	practico 25/80 / practico economic	35
4.6	Change of location	40
4.7	Transport, storage and operating conditions	40
4.8	Function notes	40
4.9	Disposal	41
4.10	Troubleshooting	42
5	Accessories	43
5.1	Special dimensions	43
5.2	Mounting accessories	44
5.3	Mattresses	46
6	Cleaning, maintenance and disinfection	47
6.1	Cleaning and care	47
6.2	Disinfection	48
6.3	Avoidance of hazards	48
7	Guidance and manufacturer's declaration	49
8	Regular inspections with service	51

1 Preface and general instructions

The various bed systems from Hermann Bock meet special requirements for the use in care and treatment facilities as well as for home care. Reliable functionality and a long product life make each bed particularly valuable. Our beds need little maintenance with proper operation and care. Each bed from Hermann Bock must pass quality testing in a final inspection before it is shipped anywhere. The beds are manufactured according to the current standards for medically used beds and tested accordingly.

The beds comply with the EN 60601-2-52 standard. The electrical building components comply with safety standard EN 60601-1 for medical devices. Nursing care beds are medical devices and are to be assigned to Class 1.

These standards divide the beds in five different areas of use:

1. Intensive care in a hospital; intensive care bed
2. Short-term care in a hospital or other medical facility; patient bed in the hospital
3. Long-term care in medical environment; stationary nursing care bed
4. Care at home, pure so-called "HomeCare bed"
5. Home-care nursing service

1.1 Intended purpose

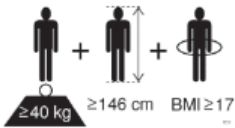

The nursing care bed is suitable for persons (adults) in need of care who are at least 146 cm tall. The person's weight may not exceed 165 kg or 185kg (depending on the model, see chapter 4.1) and must be over 40 kg. The body mass index (BMI = weight of the person (kg) / body height of the person (m)²) must be greater than or equal to 17.

The nursing care bed may be used in homes for the elderly or nursing homes and rehabilitation facilities. It is used to alleviate a disability and/or to facilitate the lives of people who are in need of care or to make the work of their caregivers easier. Furthermore, the nursing care bed was also designed as a convenient solution for the home care of frail and elderly people as well as for home care of people with disabilities. Accordingly, the nursing care beds are designed to be used for the application areas 3 to 5. Any other use is considered improper and is excluded from a possible liability claim.

The Trendelenburg function may be used exclusively under supervision of medical professionals. The beds, which are determined for environment type 4, are equipped with a hand control which is unable to operate the Trendelenburg function.

The nursing care bed is not suitable for use in hospitals. If the nursing care bed is equipped with open wheels, the nursing care bed is suitable for the transport of patients. The nursing care bed is mobile with the patient resting in it. To prepare for this, lock the castors and move the lying surface to the lowest horizontal position. Unlock the castors and move the bed. After the transport, lock the castors. If the nursing care bed is equipped with a roller cover, the nursing care bed is not designed for transporting patients. The beds can only be moved within the patient's room - even during patient positioning - for cleaning or better access to the patient, for example. If the nursing care bed is equipped with adjustable feet, it is not possible to move the nursing care bed.

The bed is suitable for the re-use. Please observe the instructions for cleaning, care and disinfection in these assembly and operation manual. Special attention must also be paid to the information regarding the inspections.

Attention: The beds come with no special connection options for a potential equalisation. Electrical medical devices connected to the patient intravascular or intracardiac may not be used. The operator of the medical products has to ensure that the combination of the equipment meets the requirements of EN 60601-1.

This user manual contains safety instructions. All persons working with the beds must be acquainted with the contents of these instructions. Improper operation can result in personal injuries.

1.2 Definition of person groups

Operator

Operators (e.g. medical supply stores, specialist dealers, facilities and cost units) include all physical or juridical persons, who use the beds or have the beds used for medical purposes. The briefing on the use of the product shall generally be conducted by the operator.

User

Users are persons whose training, experience or briefing on the product allows them to operate the nursing care bed or carry out works on it. The user is able to recognize possible hazards and/or to avoid them and to assess the health condition of the patient.

Patient/resident

Persons in need of care as well as disabled and fragile people who are lying in the nursing care bed.

Qualified personnel

Employees of the operator are referred to as qualified personnel. They are entitled to deliver the nursing care bed, assemble, dismantle and transport it, on the basis of their training or instructions. Besides knowing how to operate, mount and demount the nursing

care bed, these persons must be instructed according to the guidelines concerning the cleaning and disinfection of the nursing care bed.

1.3 Safety instructions

The intended use/operation of all moving parts is as important for the safety of the person in need of care as well as for the relatives and the caregivers/nursing staff to avoid potentially dangerous situations. This requires the correct installation and operation of the bed. The individual physique of the person in need of care as well as type and the extent of their disability must be taken into account by all means when operating the bed.

Avoid dangers, accidental motor adjustments and incorrect operation by using the disabling function. When the operator, e.g. the caregivers or the care providing relative leaves the room, the entire operating functions of the bed should be disabled via the hand control. This is achieved by operating the key of the hand control. First, lower the lying surface to the lowest position and activate the lock function with a twist of the key (located in the key lock on the backside). Remove the key and check the function of the hand control for safety reasons. Make sure that it is indeed locked.

These recommendations apply particularly:

- if the person in need of care cannot operate the hand control safely due to certain disabilities;
- if the person in need of care or the caregivers could be at risk due to those accidental adjustments;
- if the side rails are in a raised position and there could be danger of trapping and crushing,
- if children are unsupervised in the room with the bed.

Always make sure that the hand control (when not in use) is securely hooked in the support hook at the bed and cannot drop.

As a general rule, the bed should be operated by instructed nursing staff/caregivers, relatives or in attendance of instructed persons.

When adjusting the lying surface, it is particularly important to ensure that no limbs are placed within the adjustment range of the side rails. If the side rails are adjusted, pay attention to the correct lying position of the person in need of care.

Prior to making any electrical adjustment, it should, as a general rule, be made sure that no limbs are positioned in the adjustment range between the chassis and the head or foot part, especially that there are no persons or animals in the area between the floor and the raised lying surface. Danger of being crushed is particularly high in these areas. Always

beware of objects that are located close to or even below the nursing care bed. This can lead to damages.

The permitted person's weight depends on the total weight of the equipment that has been mounted to the bed (mattresses and other electronic medical devices). For safe working load, please refer to the type plate on the lying surface frame of the bed.

1.4 Service life / warranty

This nursing care bed was developed, designed and manufactured for safe operation over a long period of time. With proper operation and maintenance, this nursing care bed has an expected service life of 7 to 10 years. The service life depends on operating conditions and frequency. In the furnishing sector, for example, a service life of 15 years is to be expected.

Attention: Unauthorised technical changes to the product voids all warranty claims.

This product is not approved for the North American market, particularly not for the United States of America (USA). Distribution and use of the nursing care bed in these markets, including through third parties, is prohibited by the manufacturer.

1.5 Requirements for the installation location

The company Hermann Bock GmbH is not liable for damages which might arise from the daily usage on the floor.

To avoid floor indentations, floor should correspond to the recommendations of the FEB - Fachverband der Hersteller elastischer Bodenbeläge e. V. (Association of Elastic Floor Coverings Manufacturers). To do this, the technical information FEB No. 3 can be referenced.

Hazard note by Bock

Simultaneous use of electrical appliances particularly in the vicinity of the operational bed may result in small electromagnetic interactions of these electric devices, e.g. static noise in the radio. In such rare events, increase the distance of the devices. Do not use the same socket or temporarily switch off the interference source and/or the disturbing or disturbed device.

If the bed should be operated with electrical medical equipment (contrary to its intended use), the functions of the bed must first be disabled via the integrated locking function in the hand control for the duration of the application.

1.6 Type plate

Each nursing care bed is marked with an individual type plate. Either there is only one sticker on your nursing care bed (Fig. 1, previous nursing care bed models) or there are two separate type plates (Fig. 2, current nursing care bed models) on your nursing care bed.

Type plate for previous nursing care bed models

(1) **Model: xxx**



(2) Date of manufacturing: xx.xx.xxxx

(3) Serial no. xxxxxxxx-xxx







(4) xxx V ~ xx HZ max. x A

(5) Duty cycle xx % (x min ON / xx min OFF)

(6) Motor protection class IPX4









(7)  = xxx kg  = xxx kg

(8) Hermann Bock GmbH - Nickelstr. 12
D-33415 Verfl / Tel. +49(0)1805/262500







Made in Germany

(9)

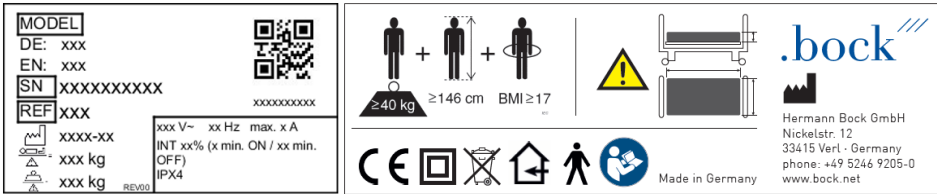
- (1) Model designation
- (2) Manufacture date: Day, month and year
- (3) Serial number: Order number - running number
- (4) Mains voltage, mains frequency and power input
- (5) Duty cycle
- (6) Drive protection class
- (7) Maximum patient weight / safe working load
- (8) Manufacturer
- (9) Symbols (located on the right side)

-  Conformity mark according to the medical device directive
- IPX4** Protection of electrical equipment against splashing water
-  Medical application part type B
-  Use only in dry rooms
-  Protection class II (double insulation, insulated for protection)
-  Within the European Union, this product must be disposed via the separated municipal waste. Product may not be disposed of as household waste.
-  Symbol for maximum patient weight
-  Symbol for safe working load
-  Symbol for observance of the user manual

Type plate for current nursing care bed models



Model Model designation in German (DE) and English (EN)

SN Serial number

REF Item numbers

Mains voltage, mains frequency, power input,

Duty cycle (INT)

Drive protection class

Date of manufacture (year-month)

Patient weight

Safe working load

Machine readable serial number

Patient population

Follow the instructions appropriate for mattress size and thickness

Conformity mark according to the medical device directive

Protection class II (double insulation, insulated for protection)

Within the European Union, this product must be disposed via the separated municipal waste. Product may not be disposed of as household waste.

Use only in dry rooms

Medical application part type B

Symbol for observance of the user manual

Address of the manufacturer

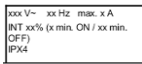

xxxxxxxxxx





2 General description of the functions

Construction design and function

Corrosion protection

The Hermann Bock GmbH nursing care beds are developed and constructed in such a way that they can function long and safely. For this reason, all materials that may corrode are protected accordingly. All metal parts are equipped with a surface protection. The steel parts are either galvanised or stove-enamelled with a PES powder coating and the aluminium profiles are anodised.

The lying surface with 4 function areas

The lying surface consists as standard of a slatted comfort frame (can alternatively be fitted with aluminium slats or special suspension systems) and is divided into four functional areas: Backrest, solid seat, upper and lower leg rest.

The comprehensive lying surface frame is welded from a steel tube. The steel tubes are stove-enamelled with a PES-powder coating. The electric variable height adjustment of the lying surface is carried out with protective low-voltage DC motors (29 to 35V), and controlled with the smooth keys of the hand controller. The backrest can be adjusted electrically. The leg part consists of a foot support that is divided into two parts. With a touch of a button on the hand control, each individual position can be adjusted continuously. In the event of a power failure, the back and leg sections can be lowered using a 9-volt battery.

The chassis

The height adjustment of the beds is carried out via a base frame with single or double drive. The surface of the tubular steel structure is stove-enamelled with a PES-powder coating.

The side rail

Each nursing care bed can be equipped on both sides with two side rails at a special safety height. The side rails can be lifted and lowered through a rail. The sliding pieces run particularly smoothly and quietly with an impact damper, and each end is fitted with a functional cap. The side rail can be easily operated through an ergonomically designed release button. Depending on the model, shorter or longer divided side rail variations are available.

*The split side rails**

The nursing care bed is optionally available with split side rails. The divided side rails serve to protect against falling out and at the same time enable safe and comfortable boarding and alighting. By means of a simple release mechanism, each individual side rails element can be brought into a raised or lowered position.

* Not available on all model series.

Operating the telescopic divided side rails

Each side rail element can be adjusted independently from the rest of the side rail parts. The release buttons for adjustment are on the bottom of the telescopic post and on the top of the appropriate end panel of the nursing care beds, right next to the metal guides for the side guard rail bars.



To lower a side rail element, grasp the upper knob of the centre post with one hand, **lift it slightly** and press the release button on the centre post inwards with the other hand (Fig. 1). The side rail opens at the corresponding place and can be easily lowered downwards as far as it will go. The side rail is now positioned diagonally (Fig. 2).

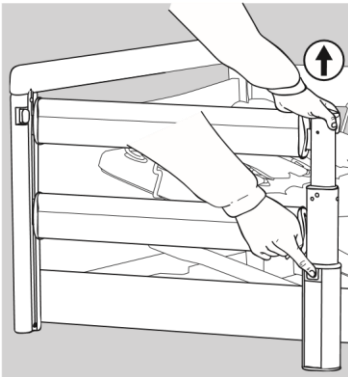

Fig. 1

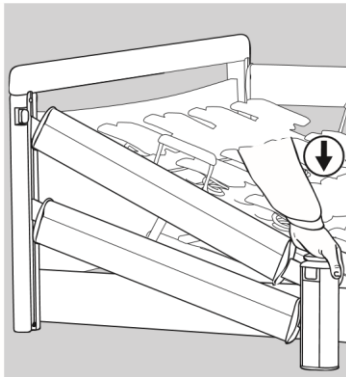

Fig. 2

To lower the other side as well, grasp the side rail on the side of the end panel in the gripping groove, release the release button on the end panel (Fig. 3) and slowly lower the side rail downwards. The side rail is now in the lowered position (Fig. 4).

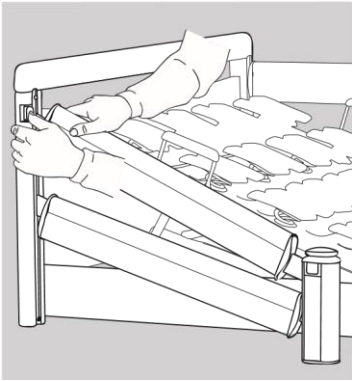

Fig. 3

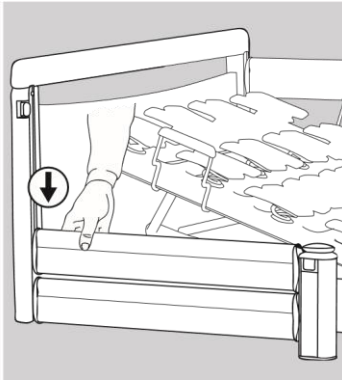

Fig. 4

If the side rail element should be placed in the top position to aid in fall prevention, reach with both hands in the centre of the gripping groove in the upper side guard rail, and pull it upwards until you hear it click into place at both ends. The side rail is now in the raised position (Fig. 5).

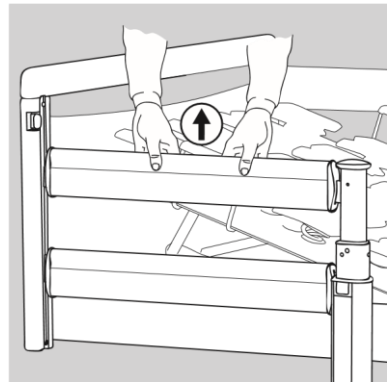

Fig. 5

The operation of the continuous side rails

The release button for adjusting the continuous side rails is located at the top of the inner sides of the head and foot panels directly next to the metal guides for the side guard rails.

If the side rails are to be lowered, grasp the provided gripping groove of the upper side guard rail (Fig. 6), lift the side rail slightly and press the release button on one side of the head or foot panel (Fig. 7). The side rail is released on the corresponding side and can easily be lowered down to the stop (Fig. 8). The side rail is now diagonal. To lower the other side as well, carry out the previously described steps on the opposite end. The side rail is now in the lowered position.

Please observe: Be sure to raise the side rail slightly, and only then press the release button!

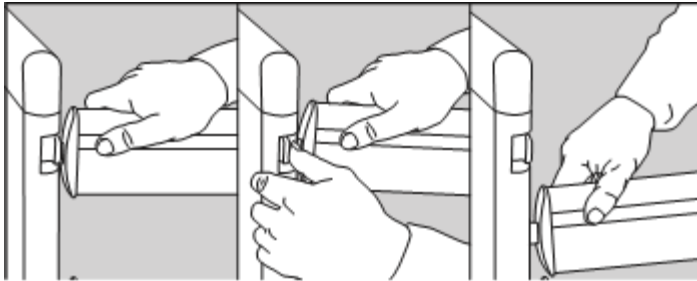

Fig. 6

Fig. 7

Fig. 8

If the side rails are to be brought into the upper position as protection against falling out, grasp the upper side guard rail in the middle of the gripping groove and pull the side rail upwards until it audibly engages at both ends. The side rail is now in a pulled-up position.

The side rails first and foremost serve as a fall prevention. In the case of very emaciated persons in need of care, this protection is no longer sufficiently provided by the side rails and additional protective measures must be taken, e.g. by adding a sliding side rail padding (accessory).

The distances of the continuous side rails must be less than 12 cm. When using the continuous side rails, they may not remain in a diagonal position.

Fig. 1: Continuous wood / steel side protection, divided into two parts

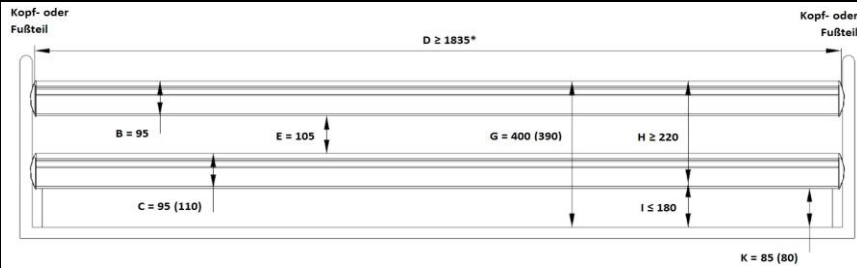

Fig. 2: Continuous wooden side rail, divided into three parts

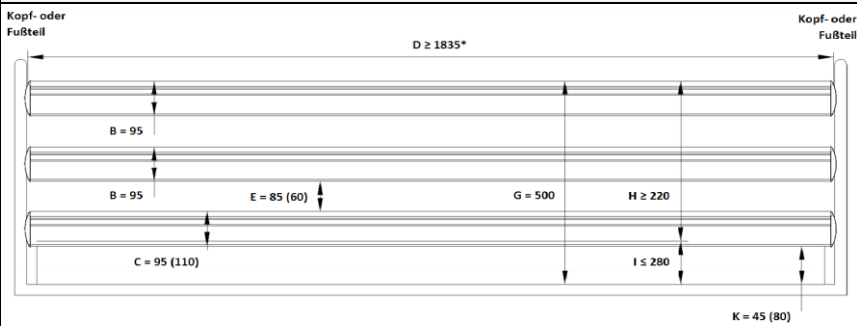

Fig. 3: Telescopic wooden side rail, double post in the middle

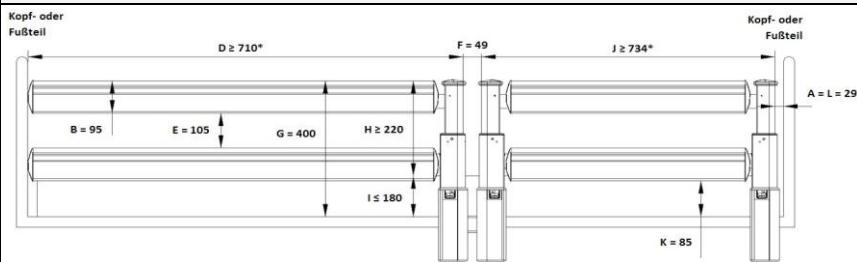
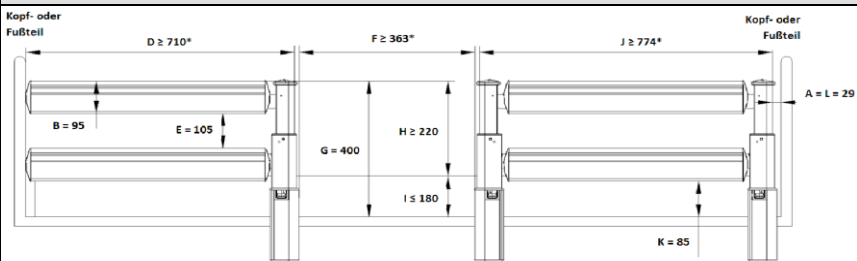

Fig. 4: Telescopic wooden side rail, solo post in the middle



Description																																																																											
All dimensions in mm. * Depending on the length of the lying surface The single post at the head and leg end is optional. The dimension in brackets is optional																																																																											
<table border="1"> <thead> <tr> <th colspan="2">Legend</th> </tr> <tr> <th colspan="2">Area Description</th> </tr> </thead> <tbody> <tr> <td>A</td> <td>Distance between the head part and the side rail</td> </tr> <tr> <td>B</td> <td>Height 1 of side rail</td> </tr> <tr> <td>C</td> <td>Height 2 of side rail</td> </tr> <tr> <td>D</td> <td>Width 1 of the side rail</td> </tr> <tr> <td>E</td> <td>Distance between the elements within the Side rail</td> </tr> <tr> <td>F</td> <td>Distance between the divided side rails</td> </tr> <tr> <td>G the</td> <td>Distance between the lying surface and the upper edge of side rail</td> </tr> <tr> <td>H</td> <td>Height of the top edge of the side rail above the mattress without compression</td> </tr> <tr> <td>I</td> <td>Thickness of the mattress for the intended use</td> </tr> <tr> <td>J</td> <td>Width 2 of the side rail</td> </tr> <tr> <td>K</td> <td>Smallest dimension between side rail and lying surface (or the panel, if any)</td> </tr> <tr> <td>L</td> <td>Distance between the foot part and the side rail</td> </tr> </tbody> </table>	Legend		Area Description		A	Distance between the head part and the side rail	B	Height 1 of side rail	C	Height 2 of side rail	D	Width 1 of the side rail	E	Distance between the elements within the Side rail	F	Distance between the divided side rails	G the	Distance between the lying surface and the upper edge of side rail	H	Height of the top edge of the side rail above the mattress without compression	I	Thickness of the mattress for the intended use	J	Width 2 of the side rail	K	Smallest dimension between side rail and lying surface (or the panel, if any)	L	Distance between the foot part and the side rail	<table border="1"> <thead> <tr> <th colspan="2">Item numbers</th> </tr> <tr> <th>Designation</th> <th>Item no.</th> </tr> </thead> <tbody> <tr> <td colspan="2">Continuous wood / steel side rail</td> </tr> <tr> <td colspan="2">Two-part (Fig. 1)</td> </tr> <tr> <td>Wood side rail (set: 95 / 95mm)</td> <td>90223</td> </tr> <tr> <td>Wood side rail (set: 95 / 110mm)</td> <td>91247</td> </tr> <tr> <td>Steel side rail (set: 95 / 110mm)</td> <td>91314</td> </tr> <tr> <td colspan="2">Three-part (Fig. 2)</td> </tr> <tr> <td>Wood side rail (set: 95 / 95mm)</td> <td>91566</td> </tr> <tr> <td>Wood side rail (set: 95 / 110mm)</td> <td>91531</td> </tr> <tr> <td colspan="2">Telescopic wooden side rail</td> </tr> <tr> <td colspan="2">Duo-post central (Fig. 3)</td> </tr> <tr> <td>Duo post</td> <td>91210</td> </tr> <tr> <td>Wood side rail (set: 95 / 95m)</td> <td>80344</td> </tr> <tr> <td>Wood side rail foot (set: 95 / 95m)</td> <td>80345</td> </tr> <tr> <td colspan="2">Solo-post central (Fig. 4)</td> </tr> <tr> <td>Solo post (head right, foot left)</td> <td>91211</td> </tr> <tr> <td>Solo post (head left, foot right)</td> <td>91212</td> </tr> <tr> <td colspan="2">Wood side rail (set: 95 / 95mm)</td> </tr> <tr> <td colspan="2">Posts at head and foot part (without Fig.)</td> </tr> <tr> <td>Solo post (head right, foot left)</td> <td>91211</td> </tr> <tr> <td>Solo post (head left, foot right)</td> <td>91212</td> </tr> <tr> <td>Wood side rail continues (set: 95 / 95mm)</td> <td>80346</td> </tr> </tbody> </table>	Item numbers		Designation	Item no.	Continuous wood / steel side rail		Two-part (Fig. 1)		Wood side rail (set: 95 / 95mm)	90223	Wood side rail (set: 95 / 110mm)	91247	Steel side rail (set: 95 / 110mm)	91314	Three-part (Fig. 2)		Wood side rail (set: 95 / 95mm)	91566	Wood side rail (set: 95 / 110mm)	91531	Telescopic wooden side rail		Duo-post central (Fig. 3)		Duo post	91210	Wood side rail (set: 95 / 95m)	80344	Wood side rail foot (set: 95 / 95m)	80345	Solo-post central (Fig. 4)		Solo post (head right, foot left)	91211	Solo post (head left, foot right)	91212	Wood side rail (set: 95 / 95mm)		Posts at head and foot part (without Fig.)		Solo post (head right, foot left)	91211	Solo post (head left, foot right)	91212	Wood side rail continues (set: 95 / 95mm)	80346
	Legend																																																																										
	Area Description																																																																										
	A	Distance between the head part and the side rail																																																																									
	B	Height 1 of side rail																																																																									
	C	Height 2 of side rail																																																																									
	D	Width 1 of the side rail																																																																									
	E	Distance between the elements within the Side rail																																																																									
	F	Distance between the divided side rails																																																																									
	G the	Distance between the lying surface and the upper edge of side rail																																																																									
	H	Height of the top edge of the side rail above the mattress without compression																																																																									
	I	Thickness of the mattress for the intended use																																																																									
	J	Width 2 of the side rail																																																																									
	K	Smallest dimension between side rail and lying surface (or the panel, if any)																																																																									
	L	Distance between the foot part and the side rail																																																																									
Item numbers																																																																											
Designation	Item no.																																																																										
Continuous wood / steel side rail																																																																											
Two-part (Fig. 1)																																																																											
Wood side rail (set: 95 / 95mm)	90223																																																																										
Wood side rail (set: 95 / 110mm)	91247																																																																										
Steel side rail (set: 95 / 110mm)	91314																																																																										
Three-part (Fig. 2)																																																																											
Wood side rail (set: 95 / 95mm)	91566																																																																										
Wood side rail (set: 95 / 110mm)	91531																																																																										
Telescopic wooden side rail																																																																											
Duo-post central (Fig. 3)																																																																											
Duo post	91210																																																																										
Wood side rail (set: 95 / 95m)	80344																																																																										
Wood side rail foot (set: 95 / 95m)	80345																																																																										
Solo-post central (Fig. 4)																																																																											
Solo post (head right, foot left)	91211																																																																										
Solo post (head left, foot right)	91212																																																																										
Wood side rail (set: 95 / 95mm)																																																																											
Posts at head and foot part (without Fig.)																																																																											
Solo post (head right, foot left)	91211																																																																										
Solo post (head left, foot right)	91212																																																																										
Wood side rail continues (set: 95 / 95mm)	80346																																																																										

Hazard note by Bock

Use only original Bock side rails, which are available as accessories for every nursing care beds. Use only technically flawless and non-damaged side rails with the permissible gap dimensions. Make sure that the side rails are engaged securely.

Before installation of the side rail and each new use, inspect all mechanical parts on the bed frame, and all parts of the side rails, and all parts which secure the side rails, for any possible damages.

The operation of the side rail should be done with great care. Fingers can be quickly pinched between the longitudinal pieces.

3 Electric parts

3.1 The drive unit

The drive unit consists of a double drive with two separate drive units for the electrically movable adjustment of the backrest and leg rest. The level adjustment of the lifting frame is adjusted via one or two individual drives (depending on the model). The level adjustment drive is connected to the control box via a helical cable. In the plug-in power supply, the input voltage is converted into a protective low voltage of maximum 35 VDC direct current. The motors and the hand control function with this non-hazardous low voltage. The cables are double-insulated and the mains plug has a primary fuse.

The internal emergency lowering is carried out via a 9 V block battery. Furthermore, power adjustment allows for constant speed of the functions. Therefore, the safety functions comply with protection class II and the moisture barrier protection type IPX4.

The maximum duty cycle is specified on the (type plate) of the bed. For example, 10% duty cycle (2 min. ON / 18 min. OFF) means that any electronic adjustment can be performed for a max. of 2 minutes within a timeframe of 20 minutes (protection against overheating).

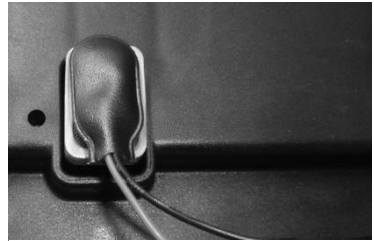

9 V block battery for emergency lowering

If the maximum setting time of two minutes is exceeded e.g. by someone continuously playing with the hand control which could lead to an overheating of the servomotors, the thermal fuse immediately shuts off the power supply to the bed. After a cooling down time of approx. one hour, the power will be automatically supplied again.

Hazard note by Bock

The 9-volt batteries in the controller should be checked once a year for their functionality and replaced if necessary. In addition, regular visual inspections must be carried out.

3.2 Caution: Electric drive

The electrically operated nursing care bed enables the person in need of care to support the recovery process psychologically and physically and at the same time relieve pain through its various functions. Electrically operated beds that are medical products need special care in regards to constant safety checks. This includes safety-conscious handling of the bed, daily inspection of electrical equipment and proper maintenance and cleaning.

To prevent damages to the cables, wiring should be conducted outside of the area in which damages could be caused. Furthermore, avoid touching the sharp parts. To prevent injury through an electric shock, avoid the possibilities of too high contact voltages. These circumstances may especially be the case if the power cable is damaged, if inadmissible and excessive leakage currents exist, or if liquid was spilled into the motor housing, e.g. during improper cleaning. This damage can cause malfunction of the control, which could result in unwanted movements of single bed elements, posing a risk of injury for the operator and the person in need of care.

Hazard note by Bock

All drive components must not be opened!

Troubleshooting or exchanging single electrical components may be performed only by special qualified personnel.

Hazard note by Bock

The motors meet the water protection standard IPX4. Do not squeeze/crush the cables. Adjustment of moving parts may only be used for the intended use. Hermann Bock GmbH assumes no liability for unauthorized technical changes.

Hazard note by Bock

Do not try to fix failures on the electrical equipment by yourself. It could be fatal! Either call the customer service of Hermann Bock GmbH or an authorised/licensed electrician who conducts the troubleshooting in compliance with all relevant VDE regulations and safety regulations.

3.3 Drives

Hermann Bock GmbH equips nursing care beds with various drive systems from Limoss (drive system with external switching power supply) and ILCON (drive system with mains isolation).

The double drive for step-less adjustment of lying surfaces and the linear drive as single drive for height adjustment of the lifting frames each consist of four main components.

- Housing
- Motor
- Gear
- Spindle with nut

The housing principle of the double drive and the single drive guarantees the permanent function of all drive components. The special design principle is based on two force-absorbing housing shells. Due to a detailed interior structure, the construction of the housing interior creates an essential prerequisite for the precise integration of the drive technology. The housing of the double drive is characterised by particularly simple assembly/disassembly and convenient installation space for the emergency lowering battery and control electronics above the powerful lateral slider.

3.4 The external switching power supply SMPS from Limoss

The Limoss drive has a primary fuse in the plug-in power supply and an emergency lowering device. The plug-in part of the external switch mode power supply (SMPS) is an electronic transformer, which warms up only to a minimum degree under load and it is equipped with electronic performance monitoring. The result is a constant voltage up to the maximum load (no loss of speed) and a high level of protection against overloading. The external transformer ensures safety right from the socket because it converts the voltage directly into the safety low-voltage which is used to actuate the bed. It is connected via plug coupling to the mains supply line feeder cable and can be replaced separately if defective.

The plug-in part of the external switch mode power supply complies with the European directives for electrical household appliances. In standby mode, it also has a low energy consumption of maximum 0.5 Watt and can be used internationally with variable input voltages from 100 V to 240 V. Electromagnetic alternating fields are not measureable on the SMPS adapter and in operation still lower than mains isolation.



The external switch mode power supply

3.5 The mains isolation from ILCON

In addition to a high safety guarantee, the integrated ILCON mains isolation in the mains plug offers further practical advantages in use. When disconnected from the mains, the mains isolation prevents magnetic and electrical alternating fields in the bed. The mains isolation works independently of the mains and does not require an additional transformer for its "stand-by". When the drive is enabled, no power is consumed and a switching noise in the relay signals correct operation. Of course, the mains isolation is compatible with higher-level mains isolation switches. The ILCON mains isolation in the mains plug is activated by pressing the hand control button. A capacitor charged with direct current in the drive supplies current to the 2-pole relay in the mains isolation and switches the transformer in the drive on. This recharges the capacitor and prepares it for the next operation. After each release of the hand control key, the relay in the mains isolation switches off the house mains 2-pole. A switching noise signals the execution of this function.

The 9-volt battery for the emergency movement, installed as standard in the control unit, buffers the mains isolation capacitor if necessary, if it has not been used for a long time and has thus lost its voltage. If the capacitor and the 9-volt buffer battery are exhausted, just press the green button and the mains isolation works normally again. Each time the bed is taken out of service, the contact to the 9-volt buffer battery must be disconnected by removing the plug.



Mains isolation

Plug variants

3.6 The ICS drive system

Intelligent control systems (ICS) are capable of reliably controlling and monitoring the components and parameters of a bed. This microprocessor control can be perfectly adapted to your applications by the individual adjustment of more than 100 parameters. The ICS system automatically recognizes which system it is and uses the system-related parameters stored in advance.

Product features:

- Soft control
- Synchronous run
- Memory function
- Special functions and sequence control, e.g. maintenance position or parallel adjustment of all 4 motors, e.g. for the seat position
- Modular design, i.e. special functions programmable on customer request
- Easily programmable, approx. 100 parameters (pre)adjustable
- Safe shutdown and final position, e.g. protection against collision

3.7 The system moves without adequate permission

If the system moves without permission, for example, too early into the incline, the position is considered as lost. This can occur, for example, by replacing the drives. An initialization must be carried out to correct the error. The initialization is carried out with a key combination using the third pair of keys from above (auto contour). The two keys are pressed and held until the initialization is complete. After about five seconds, all the drives will shut down at half the speed. Because of the half speed it is possible to prevent collisions in time.

3.8 Resetting the position after triggering the MSE

After the release of the mechanical quick release, the position of the drive no longer corresponds to the stored position. For this reason, the drive concerned must be reset to zero. To do this, press the "down" key of the corresponding drive until the drive has reached the lower control limit switch. The drive was successfully reset and can now be moved as usual.

3.9 The hand control

The hand control is equipped with a built-in locking device, which allows the caregivers to lock the hand switch via a key completely or partially for its operation.

The lockable hand control, first-fault protected

The base functions can be controlled safely through the six respectively ten extra-large keys with finger pressure on the ergonomically designed hand control. The individual keys

are marked with corresponding symbols. The servomotors run until as long as a corresponding key is pressed and held. A coiled cable allows the necessary freedom of movement while operating.

With the rear-mounted suspension unit, the hand control can be attached to the side rail - particularly when cleaning and during the maintenance of the bed. Thus, a possible disruptive position of the hand control can be avoided by simply attaching it to any preferred spot on the bed.



- Back part upwards
- Back part downwards
- Lower leg part upwards
- Lower leg part downwards
- Auto contour upwards *
- Auto contour downwards *
- Lying surface upwards
- Lying surface downwards
- Low foot support (Anti Trendelenburg) *
- Head-lowering position (Trendelenburg) *
- Comfort sitting position * (upwards only **)
- Enable low function *
- Reset *
- Lighting on/off *



Examples for different hand controls

* availability depends on the model

** Comfort sitting position only moves up. All adjusted positions must be lowered separately.

Hazard note by Bock

Do not exceed the maximum duty cycle of 2 minutes. Observe a subsequent break of at least 18 minutes by all means.

Hand control - lock functions

The hand control comes with an integrated disabling function that can be activated and deactivated with the corresponding key. To disable the entire electrical function, insert the key in the key lock on the backside and turn the lock function on or off with a corresponding twist of the key.

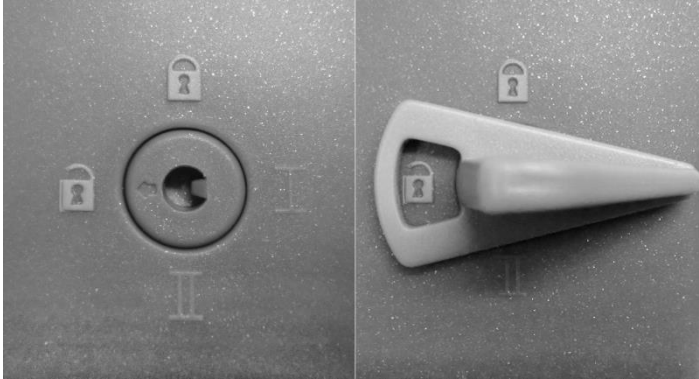

Key for locking device

Locking device 1

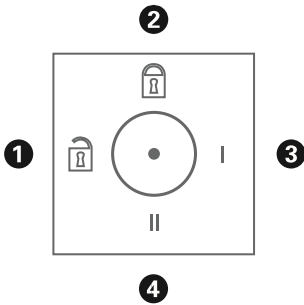

2	All hand control functions disabled
1, 3, 4	All functions executable

Locking device 2

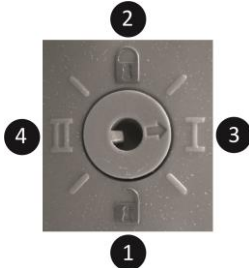

1	Only Trendelenburg function disabled
2	All hand control functions disabled
3 + 4	All functions executable (including Trendelenburg function, if available)

4 Assembly and operation

4.1 Technical data

Technical data		belluno	livorno low	combiflex / combiflex.fc	practico 25/80	practico economic
Lying surface dimension: cm		90 x 200	90 x 200	90 x 200	90 x 200	90 x 200
Outer dimension: cm		103 x 213	105 x 212	103 x 203	105 x 210	105 x 210
safe working load: kg		200	200	220	220	220
max. Weight of person: kg		165	165	185	185	185
Height adjustment: cm		37 – 82,5	37 – 83 / 28.5 – 72.5	38 - 81	25 – 80	25 - 80
Length of backrest (mc = mattress compensation): cm		66 / 78 (mc)	78 (mc)	78 (mc)	78 (mc)	66 / 78 (mc)
max. Angle of incidence to horizontal:						
- back part		70°	70°	70°	70°	70°
- Lower leg part		20°	20°	20°	20°	20°
- Trendelenburg position (optional)		n. possible	n. possible	15°	15°	15°
Side rail height with spring strips: cm		39	40	39 / 40	40	39
Selection options for side rails:						
- continuous wood / steel side rail:		•	•	•	•	•
- Wood side guard telescopic divided		n. possible	•	•	•	n. possible
Lifter bottom space clearance: cm		15	15	15	15	15
Sound level: dB (A)		< 65	< 65	< 65	< 65	< 65
Weights:						
Total incl. continuous Wood side rail: kg		98	109	80	147	157
Lying surface: kg		38	42	38	50	50
Chassis: kg		37	37 / 39	42	53	53
Wood end panel: kg		12	10	10	12.5	12.5
Continuous Continuous side rail: kg/set		11.5	11.5	11.5	11.5	11.5
Continuous Steel side protection: kg / set		15.8	15.8	15.8	15.8	15.8
Telescopic wooden side rail: kg/set		n. possible	18	18	18	n. possible
Special dimensions length: cm		180 - 220	180 - 220	190 - 220	200 - 220	200 - 220
Special dimensions Width: cm		80 - 140	80 - 140	80 - 140	90 - 140	90 - 140
Electric data						
Ilcon	Input voltage: V	230	230	230	230	230
	Frequency: Hz	50	50	50	50	50
	max. Power consumption: A	2	2	2	2	2
Limoss	Input voltage: V	100 - 240	100 - 240	100 - 240	100 - 240	100 - 240
	Frequency: Hz	50/60	50/60	50/60	50/60	50/60
	max. Power consumption: A	2.1	2.1	2.1	2.1	2.1

All parts and data are subject to a constant further development and therefore may differ from the mentioned data.

Please note that the beds are also available in special sizes, whereas the technical data may vary accordingly.

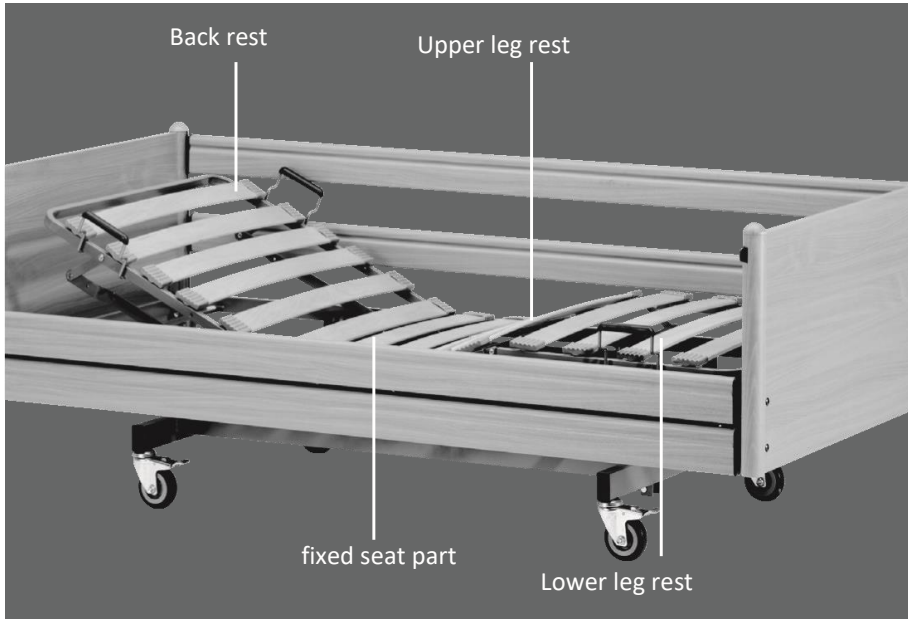

4.2 belluno

belluno is the classic solution for daily continuous use in rehabilitation and care facilities as well as in home care. belluno offers frail people, patients in need of care and people with disabilities a high degree of lying comfort and at the same time supports optimum care through its easy operation.

- belluno is not suitable for hospital use.
- belluno is suitable for the transport of patients. The nursing care bed is mobile with the patient resting in it. To prepare for this, lock the castors and move the lying surface to the lowest horizontal position. Unlock the castors and move the bed. After the transport, lock the castors.
- belluno is suitable for persons in need of care (adults) with a height of 146 cm or more. The person's weight may not exceed 165 kg and must be over 40 kg. The body mass index (BMI) must be greater than or equal to 17.
- Under certain circumstances belluno can be used (if necessary) for medical purposes with other electric medical equipment (e.g. suction devices, ultrasonic humidifier, food systems, anti-bedsore systems, oxygen concentrators and similar devices). In this event, disable all bed functions for the duration of the application via the integrated disabling function.

Attention: The bed has no special connection options for a potential equalisation. Electrical medical devices connected to the patient intravascular or intracardiac may not be used. The operator of the medical products has to ensure that the combination of the equipment meets the requirements of EN 60601-1.

Special features

belluno offers modern, reliable technology with an easy operation in various function variants. belluno is available with a 4 or 5-split function of the lying surface. The electrical adjustment of the back part of the lying surface is carried out via the hand control. With the 4 or 5-split lying surface, the back and leg sections are electrically operated via the hand control with automatic 3-fold adjustment.

belluno becomes operational

Before you begin with the assembly, all packaging residues must be completely removed. Place the chassis with scissor component free-standing and lock the castors.



When assembling the divided lying surface, first move the scissor component to knee height using the box motor. Then place the head-side lying surface element on the ball bearings and then fasten the foot-side lying surface element using the split pins. Secure the split pins against unintentional loosening with the cotter pin. Push the two lying surface elements together, and tighten them on both sides with the included Allen key using the previously removed screws. Latch in and close the motor according to the markings (head/foot side).



When mounting the undivided lying surface, the ball bearings in the upper area of the scissor component must be inserted into the U-profile at the lower end of the lying surface which is provided for this purpose. Remove the spring cotter pins from the chassis. Lock the lying surface between the two brackets with the previously removed split pin. Secure the split pins against unintentional loosening with the cotter pin.

The power cable must be screwed to the lug of the lying surface with the strain relief provided on the cable. Connect the mains plug. Connect the hoist motor to the lying surface motor.

Push one end piece on one side completely. The release button must snap into the hole in the lying surface. Push on the second end piece only up to directly in front of the release button.

Then hook the side rails into the pre-assembled metal guides and arrange them.

Absolutely **MAKE SURE** to read the labels attached on the top and bottom of the side rails so these may not be mixed up with each other.

Press down on the release button and push in the second end piece until it engages firmly in the hole provided for it.



After assembly or before putting the bed into operation, move the adjustment range of the lying surface over the control unit to check the optimum positioning of the cables. The adjustment range must be passable without obstacles. The power cable must be routed outside the bed and the hand control must be exposed.



4.3 livorno low

livorno low was specially designed for the requirements of daily continuous use in rehabilitation and care facilities, as well as in the home care environment. They offer frail people, patients in need of care and people with disabilities a particularly homely environment, comfortable conditions and at the same time support optimal care.

- livorno low is not suitable for hospital use.
- livorno low is suitable for the transport of patients. The nursing care beds are mobile while the patient resting in them. To prepare for this, lock the castors and move the lying surface to the lowest horizontal position. Unlock the castors and move the bed. After the transport, lock the castors.
- livorno low is suitable for persons in need of care (adults) with a height of 146 cm or more. The person's weight may not exceed 165 kg and must be over 40 kg. The body mass index (BMI) must be greater than or equal to 17.
- livorno low may be operated (if required) for medical purposes with other electrical medical devices (e.g. suction devices, ultrasonic nebulizers, feeding systems, anti-bedsore systems, oxygen concentrators, etc.). In this event, disable all bed functions for the duration of the application via the integrated disabling function.

Attention: The bed has no special connection options for a potential equalisation. Electrical medical devices connected to the patient intravascular or intracardiac may not be used. The operator of the medical products has to ensure that the combination of the equipment meets the requirements of EN 60601-1.

Special features

livorno low has mature technology and can be integrated particularly well into existing living areas thanks to the selection of decorative elements. The lying surface is optionally available with a 4 or 5-split function. On the lying surface, the back and leg sections are electrically operated via the hand control, whereby the leg section is equipped with automatic 3-fold adjustment.

livorno low become operational

Before you begin with the assembly, all packaging residues must be completely removed.

Place the chassis with scissor component free-standing and lock the castors. To simplify the assembly, we recommend that you first raise the scissor component to knee height by connecting them to the lying surface motor.

When mounting the lying surface, the ball bearings in the upper area of the scissors must be inserted into the U-profile provided for this purpose at the lower end of the lying surface. Remove the spring cotter pins from the chassis. Lock the lying surface between the two brackets with the previously removed split pin. Secure the split pins against unintentional loosening with the cotter pin.

The power cable must be screwed to the lug of the lying surface with the strain relief provided on the cable. Connect the mains plug. Connect the hoist motor to the lying surface motor.

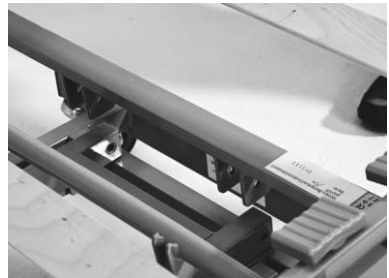
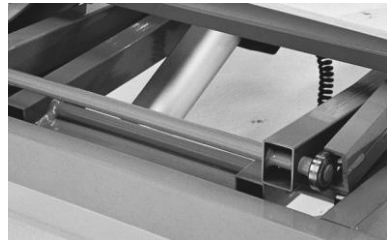

Mount the side panels to the longitudinal frames using the screws provided.





4.4 combiflex / combiflex.fc

combiflex and combiflex.fc have been specially designed to meet the requirements of care at home and in rehabilitation and care facilities. They offer frail people, patients in need of care and people with disabilities the opportunity to support an optimal care in their familiar surroundings.

- combiflex is not suitable for hospital use.
- If the combiflex is not equipped with adjustable feet, the nursing care bed is suitable for transporting patients. The nursing care bed is mobile with the patient resting in it. To prepare for this, lock the castors and move the lying surface to the lowest horizontal position. Unlock the castors and move the bed. After the transport, lock the castors.
- combiflex is suitable for persons in need of care (adults) with a body height of 146 cm or more. The person's weight must not exceed 185 kg and must be over 40 kg. The body mass index (BMI) must be greater than or equal to 17.
- Under certain circumstances combiflex can be used (if necessary) for medical purposes with other electric medical equipment (e.g. suction devices, ultrasonic humidifier, food systems, anti-bedsore systems, oxygen concentrators and similar devices). In this event, disable all bed functions for the duration of the application via the integrated disabling function.

Attention: The bed has no special connection options for a potential equalisation. Electrical medical devices connected to the patient intravascular or intracardiac may not be used. The operator of the medical products has to ensure that the combination of the equipment meets the requirements of EN 60601-1.

Special features

The combiflex offers proven and modern technology with an automatic full function for 4-fold adjustment of the lying surface for home use. If required, each possible automatic lying surface adjustment can be individually adjusted up to the sitting position.

Thanks to its extremely low installation height, the combiflex bed-in-bed system can be combined with almost any existing bed frame, thus offering a high degree of individuality at any deployment location.

The combiflex nursing care bed is available with an extended hand control function to support Trendelenburg positioning.

The combiflex becomes operational

Before you begin with the assembly, all packaging residues must be completely removed.

Place the two parts of the chassis free-spaced.

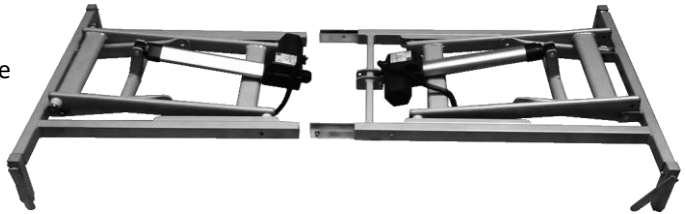

Insert the two halves of the chassis into each other, but do not push them together completely.



Latch in the lifting motor, insert bolts and secure with safety pin.



Push the halves of the chassis together completely and screw them together tightly.



Push the two halves of the lying surface together and tighten with the screws provided.



Attach the box motor to the lifting parts of the lying surface. The box motor is fixed with the locking sliders on both sides. Be sure to push the locking sliders to the stopper as far as they will go.

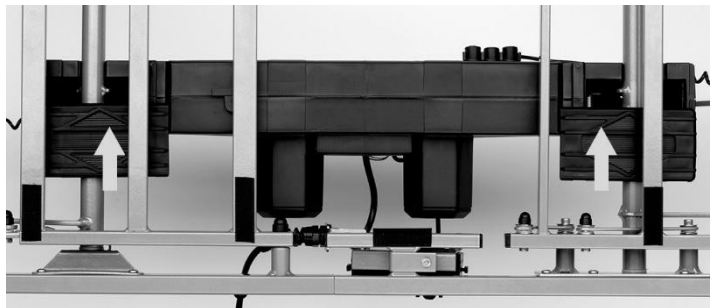

Take the lying surface and connect it to the chassis so that the ball bearings in the upper part of the chassis can be inserted precisely into the U-profile on the underside of the lying surface.

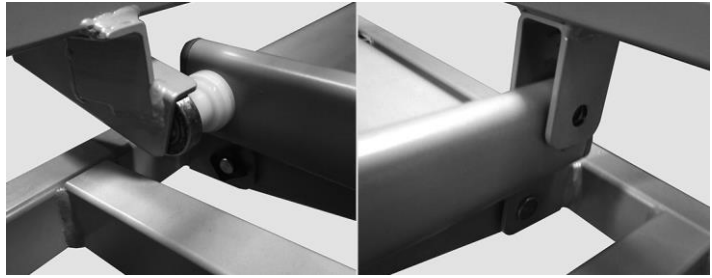

Then fasten with the supplied bolts and secure with the locking plate.



The power cable must be screwed to the lug of the lying surface with the strain relief provided on the cable.

Insert the plugs on the cable end of the hoist motors of the chassis into the matching sockets on the box motor.

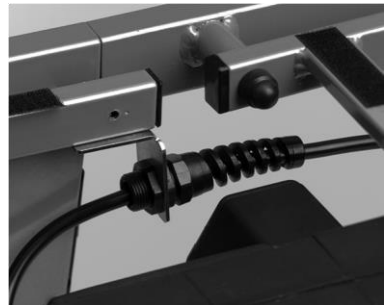

After assembly or before putting the bed into operation, move the adjustment range of the lying surface over the control unit to check the optimum positioning of the cables. The adjustment range must be passable without obstacles. The power cable must be routed outside the bed and the hand control must be freely accessible.



4.5 practico 25/80 / practico economic

practico 25/80 and practico economic were specially designed for the requirements of the daily continuous use in inpatient and home care. They offer frail people, patients in need of care and people with disabilities comfortable conditions and support optimal care.

- practico 25/80 and practico economic are not suitable for hospital use
- If the practico models are equipped with open castors, the nursing care beds are suitable for transporting patients. The bed is mobile with the patient resting in it. To prepare for this, lock the castors and move the lying surface to the lowest horizontal position. Unlock the castors and move the bed. After the transport, lock the castors. If the nursing care bed is equipped with a roller cover, the bed is only suitable to be moved for cleaning purposes inside the patient's room or to allow access to the patient.
- practico 25/80 and practico economic are suitable for persons in need of care (adults) with a height of 146 cm or more. The person's weight must not exceed 185 kg and must be over 40 kg. The body mass index (BMI) must be greater than or equal to 17.
- practico 25/80 and practico economic can under certain circumstances (if required) be operated for medical purposes with other electrical medical devices (e.g. suction devices, ultrasonic nebulisers, feeding systems, anti-bedsore systems, oxygen concentrators, etc.). In this event, disable all bed functions for the duration of the application via the integrated disabling function.

Attention: The bed has no special connection options for a potential equalisation. Electrical medical devices connected to the patient intravascular or intracardiac may not be

used. The operator of the medical products has to ensure that the combination of the equipment meets the requirements of EN 60601-1.

Special features

The sophisticated lifting technology below the lying surface lends these beds their elegant silhouette. It offers the entire spectrum of technical comfort. If required, every possible automatic lying surface adjustment can be individually adjusted up to the seating comfort position.

The model with a central locking of the brakes is also available without a full fairing of the castors. The nursing care beds of the practico series are available with both split and continuous side rails and various wood end panels for head and foot parts.

The practico lying surface is available with a 4-part lying surface. The electrical adjustment of back and leg section is carried out with an automatic 3-fold function. The practico nursing care bed is optionally equipped with a Trendelenburg bearing or a comfort sitting position.

The practico becomes operational

Before you begin with the assembly, all packaging residues must be completely removed. Place the chassis with fixed castors free-standing on the floor and move it up. Take the pre-assembled lying surface with box motor and connect it to the free-standing chassis in such a way that the ball bearings in the upper area of the chassis can be inserted precisely into the U-profile provided for this purpose at the lower end of the lying surface. Then tighten with the included screws.

The power cable must be screwed to the lug of the lying surface with the strain relief provided on the cable.

Connect the mains plug. Insert the plug at the cable end of the hoist motor into the suitable socket of the box motor and raise the lying surface.

Mount the side panel to the longitudinal frame using the screws provided (does not apply to practico economic).

Assembly of the continuous side guard rails

Push one end piece completely on the head side and screw tight. Push the second end piece only up to directly in front of the bore hole.



Then hook the side rails into the pre-assembled metal guides and arrange them. Absolutely **MAKE SURE** to read the labels attached on the top and bottom of the side rails so these may not be mixed up with each other.

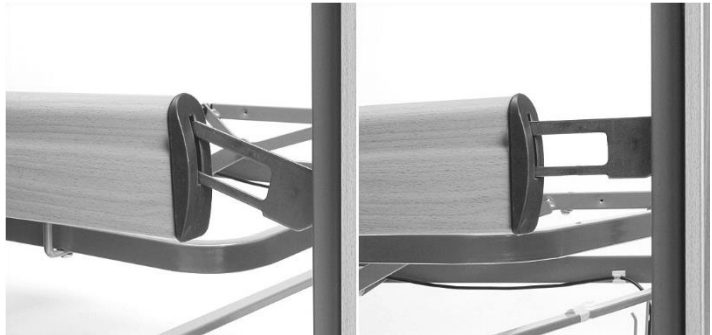

Assembly of the telescopic split side guard rails

With this side guard rail variant, both end pieces may not be fully assembled. Both end pieces should only be fitted loosely and not screwed together.

Take the side panel and screw it into the fixing holes on all sides of the lying surface frame.

Attach the U-profile of the telescopic centre posts to the frame of the lying surface. The holes of the U-profile and the lying surface frame must lie on top of each other. Insert the supplied screws from above into the drill hole and screw tightly.

Take the side guard rails and hook them into the pre-assembled metal guides on each side and arrange them. Please pay attention to the markings on the top and bottom of the side guard rails.

Finally push on the end pieces completely and screw them tightly. The side rails are now ready for use.

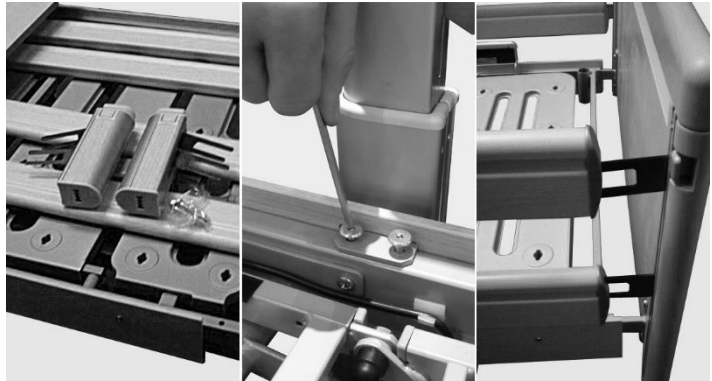

After assembly or before putting the bed into operation, move the adjustment range of the lying surface over the control unit to check the optimum positioning of the cables. The adjustment range must be passable without obstacles.

The power cable must be routed outside the bed and the hand control must be exposed.

Bed extension (models belluno, combiflex, combiflex.fc and pratico economic)

The delivery for a lying surface extension consists of the following parts:

- 2 adapter unit for the left and right foot part
- 1 extension piece for the foot part
- 1 set side rails
- Fixing screws



Proceed as follows to install the unit:

1. Remove the mattress from lying surface.
2. Remove the foot end piece.
3. Insert the adapter pieces at the foot end into the lying surface frame and screw them together.
4. Place the wire bracket on the foot part, drill holes (d = 4.2 mm) and screw them together.
5. Slide the foot end piece flush with the threaded hole to the lying surface frame.
6. IMPORTANT: Make sure to read the labels attached on the top and bottom of the side rails so these may not be confused with each other.
7. Then hook the side rails into the pre-assembled metal guides and arrange them.
8. Finally push on the end pieces completely and screw them tightly.

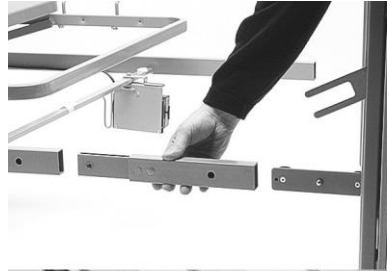

Bed extension (models pratico 25/80 and livorno low)

The delivery for a lying surface extension consists of the following parts:

- 1 locking element for the lying surface incl. side panel extension
- 1 set of longer side rails

Proceed as follows to install the unit:

1. Remove the mattress from lying surface.
2. Loosen the screw connection of the foot end piece and pull out the extension, removing the side rails.
3. Insert and screw the locking element for the lying surface incl. panels.
4. Install the side rails.
5. Push the foot end piece flush in front of the side panels and screw it in place.

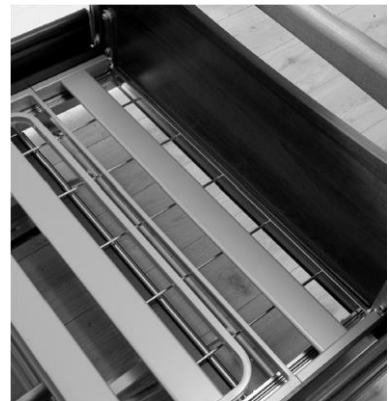

4.6 Change of location

If the bed must be moved to another location, please follow these safety instructions:

- Bring the lying surface to the lowest position.
- Before proceeding, pull out the mains plug and attach with the suspension device at the side rail, to secure the power cable against falling and being crushed through over-travel. Make sure that the cable is not dragged over the floor.
- Before inserted the mains plug again, inspect the power cable visually for mechanical damage (dents and kinks, abrasions and bare wires).
- Place the power cable in a way that it will not be rolled over or strained during the operation of the bed or could be damaged when inserting the mains plug again.

4.7 Transport, storage and operating conditions

	Transport and storage	Operation
Temperature	0°C to +40°C	10°C to +40°C
Relative humidity	20% to 80%	20% to 70%
Air pressure	800hPa to 1060hPA	

4.8 Function notes

To fix the bed in place, the brakes on the castors (if any) of the chassis must be locked. To accomplish this, use your foot to move the locking lever on the chassis downwards.

If necessary, pull the integrated side rails up until they lock into place. When using mattresses of different thickness, the minimum height of 22 cm, measured from the top edge of the side rail above the mattress without compression, may not be underrun (additionally, a third attachment guard must be used).



4.9 Disposal

Each of the components made of plastic, metal and wood are recyclable and can be disposed/recycled in compliance with the relevant legal provisions. Please note that electric adjustable nursing care beds or nursing beds are considered commercially used electronic scrap according to the WEEE-EC directive 2012/19/EC (b2b). All replaced electrical and electronic components of the electrical adjustment system must be handled in accordance with the requirements of the Electrical and Electronic Equipment Act (ElektroG) and disposed of properly.

4.10 Troubleshooting

This overview helps you to detect and correct malfunctions on your own and explains, what kind of malfunctions require the consultation of suitably qualified service personnel.

Malfunction	Potential causes	Remedy
The drive units cannot be controlled via the hand control	Power cable is not connected	Insert power cable
	No voltage in the socket	Check the socket or the fuse box
	Plug connector of the hand control not fixed firmly	Check the plug-in connection on the motor
	Hand control or drive unit defective	Notify the operator or Bock customer service
	Mains isolation not activated	Activate the mains isolation by pressing the green button, additionally check the 9V battery
	Disabling function or control box in the hand control activated	Disabling function or control box in the hand control deactivated
When buttons are pressed, the drive units stop after a short time	There is an obstruction in the adjustment range	Remove obstruction
	The safe working load has been exceeded	Reduce the load
The drives stop after a longer adjustment time	The adjustment time or safe working load has been exceeded and the polyswitch in the transformer of the control unit has responded to increased heat	Allow the drive system to cool down sufficiently for at least one minute
Opposite functions when operating the hand control	Motor connector switched internally	Notify the operator or Bock customer service
Individual drive units run in one direction only	Hand control, drive unit or controller defective	Notify the operator or Bock customer service
Drive units stop and bed remains in a tilted position	Constant operation of adjustment functions	Move the lying surface to its lowest position and align it again horizontally. Activate disabling function in hand control

5 Accessories

Hermann Bock GmbH offers practical and mobility-promoting accessories to ensure that each nursing care bed is tailored even more precisely to the individual needs of the person in need of care. The installation is done in a quick and easy manner using the fixing points on the bed that have already been prepared for this purpose. It goes without saying that every element of our additional equipment offer meets the special quality and safety standards of Bock. In addition to the standard accessories included in basic equipment, the customer can also choose from our variety of accessories, which is available for each bed model. These optional accessories vary depending on the bed model and are fitted to its special functions and location of use. The range stretches from technical elements over mattresses up to the occasional extra bed. A wide range of wooden finishes and a variety of colours allow for the harmonious integration of each nursing care bed with any kind of furniture.

5.1 Special dimensions

Special dimensions are an essential part of the production Hermann Bock GmbH. Optimal lying comfort for persons in need of care who have a particular physique can only be achieved by means of custom-built models. With its customized models, Hermann Bock GmbH enables customers to have their nursing care bed tailored to fit the individually physical requirements of the person in need of care. For body heights up from 180 cm, Hermann Bock GmbH recommends the use of a bed extension that allows an extension of the lying surface to a length of up to 220 cm. This enables even tall people to lie comfortably while maintaining the same level of functionality.

Hazard note by Bock

When using accessories on the bed or medically necessary devices as infusion stands in close proximity to the bed, ensure particularly that there are no risks of crushing or shearing for the caregiver when adjusting the back and leg rests.

The representative of the service hotline of Hermann Bock are looking forward to informing you about the best retrofitting solution for your bed. Hotline no. 0180 5262500 (14 cents/min. for calls from landline phones, 42 cents/min. for calls from mobile phones).

A wide product range of auxiliary furniture complements the various bed models up to the complete interior design of your home. This combination creates a care and living comfort resulting in perfect harmony.

5.2 Mounting accessories

The following standard accessories can be combined with the bed models:

Side rail height increase:

Delivery includes:

Fully assembled side rail height increase

- Open the plastic lock, attach the side rail extension, position it in the middle and close the lock. Please make sure that the release button of the side rail height increase faces outwards.

Important note:

The Bock side rail height increase is designed for use with all Bock wood side rail variants. Hermann Bock GmbH does not accept any liability for the use of these products on other makes!



Lifting pole with triangle handle, 6.5 kg

The safe working load of the lifting pole is max. 75 kg.

Delivery includes:

1 piece lifting pole with hook-up loop

1 piece triangle

- Place the lifting pole with triangle handle in the provided hook-up loop at the head part and adjust it accordingly.
- Make sure to only use mattress with a required mattress height as described by the company Bock. You can find this information in section 5.3.



ATTENTION: The lifting pole with a triangle handle must not swivel outside of the lying surface.

When used in line with its intended purpose, the service life of the triangle handle is approx. 5 years. If a lifting pole with triangle handle installed to the bed, it must be tested during each safety technical control, but must be replaced no later than after 5 years.

The handle can be infinitely adjusted within a range of 350mm. This allows an adjustment range between triangle handle and mattress of at least 550mm to 850mm, depending on the mattress thickness. The total height of the nursing care bed increases by 1300 mm when using a lifting pole.

Side rail guard pad, 1.4 kg

Delivery includes:

1 piece cover

1 piece padding

- Open the zipper of the cover, pull the padding onto the side rail from above
- Pull the foam padding from the inside of the bed into the fabric and close the zipper and/or the hook and loop fastener.



Tray, 4.0 kg

Delivery includes:

1 piece tray

- The tray is applied to the side rail and prevented from getting out of place using two spacer pieces.



Assist handle with holder for scissor-type beds, 3.0kg

Delivery includes:

1 piece assist handle with holder



- Loosen the four screws on the holder.
- Place the plates of the holder on the crossbar and screw them together.

- Push the assist handle into the holder, adjust it to the desired position and screw it tightly.



5.3 Mattresses

In general, foam and latex mattresses are suitable for the Hermann Bock nursing care beds. A volumetric weight of at least 35kg/m^3 is required along with the dimensions of 90 x 190 cm, 100 x 190 cm, 90 x 200 cm and 100 x 200 cm.

The height of the mattress used may not exceed:

- 15 cm for aluminium or springwood lying surfaces (belluno, combiflex, combiflex.fc and practico economic) or 16 cm (practico 25/80 and livorno low) and
- 12 cm for lying surfaces with spring systems

For higher mattresses, an additional attachment guard device must be used, which is available as an accessory. When using foam mattresses, we recommended the use of a cut foam mattress to allow a better combination with the lying surface.



Hazard note by Bock

For safety reasons use only original Bock accessories when furnishing your nursing care bed further. Those accessories must be approved by Hermann Bock for the respective bed model. A detailed overview of the accessories and extras for your bed can be found on a separate data sheet. Hermann Bock assumes no liability for accidents, damages and hazards arising from the use of other accessories!

6 Cleaning, maintenance and disinfection

The individual bed elements consist of high quality materials. The surfaces of the steel tubes is covered with a durable polyester-powder coating. All surfaces of the wooden parts are surface-sealed with an ecologically coating that is low on harmful substances. All bed elements are easy to clean and cared for using wipe and spray disinfection means according to the applicable cleaning requirements with respect to the various areas of application. Observing the following care instructions will retain the usability and visual appearance of your nursing care bed for a long time to come.

6.1 Cleaning and care

Steel tubes and vanished metal parts:

Please use a wet wipe and a regular mild household detergent for the cleaning and care of these surfaces.

Wooden-, decorative-, and plastic elements:

All standard furniture cleaners and cleaning detergents can be used. Using a wet wipe without detergent additives for the cleaning of the plastic elements should generally be sufficient. For care of the plastic surfaces use a product that is specifically suitable for plastics.

Drive:

To prevent the intrusion of moisture into the motor housing, we recommended using only a damp rag to clean outside housing.

Spring systems ripolux neo:

Use a damp rag without adding any detergents, or, if deemed necessary, a detergent that is exclusively suitable for plastics and clean the spring elements made of plastics. In case of heavy contamination, remove the spring elements from the supporting elements and the supporting elements from the frame of the lying surface. The dismantled plastics elements can be rinsed or spray-washed with hot water to get them clean. For the disinfection, the components should be sprayed with a detergent suitable for plastics. Most of the moisture drips off the plastic surface by slightly shaking it, while the rest will dry on its own within a very short time. Remount the elements after they have completely dried. If required, you can also remove each of the individual lying surface elements completely from the frame to clean them.

6.2 Disinfection

Disinfect the nursing care bed with a wipe disinfectant. Please adhere to the tested and recognised procedures of the Robert Koch Institute (RKI). You can use commercially available cleaning and disinfecting agents approved by the RKI. In order to maintain the material resistance of the plastic elements such as the motor housing and decorative elements, only mild and gentle agents should be used for disinfection. Concentrated acids, aromatic and chlorinated hydrocarbons as well as detergents containing highly concentrated alcohols, ether, ester and ketone may damage the material and should therefore be avoided. The list of disinfectants and disinfection methods tested and approved by the Robert Koch Institute can be found on the Internet at www.rki.de.

6.3 Avoidance of hazards

In order to avoid dangers in connection with cleaning and disinfection, you must first observe the following regulations in connection with the electrical components of your nursing care bed. Non-observance of these guidelines may result in considerable damage of the electrical lines and the drive.

1. Pull the mains plug and position it in such a way that contact with excessive amounts of water or detergents can be excluded.
2. Check all plug-connections for correct position according to the instructions.
3. Check the cables and electrical component parts for damage. Should you detect any damage, do not perform any cleaning operations but first have the defects repaired by the manufacturer or an authorised/ licensed electrician.
4. Before starting the operation, check the mains plug for residual moisture and dry or blow out the device, if necessary.
5. On any suspicion of the intrusion of moisture into the electrical components, disconnect the mains plug immediately and do not re-establish the connection. Put the bed out of operation immediately, attach an appropriate visible label and contact the manufacturer/supplier.

Hazard note by Bock

Use of abrasive cleansers and/or detergents containing grinding particles, cleaning pads or stainless steel cleaners for the cleaning is absolutely not recommended. Neither use organic solvents such as halogenated/aromatic hydrocarbons and ketones nor detergents containing acid or alkaline.

Under no circumstances must the bed be sprayed with a water hose or high-pressure cleaner, as liquid penetrates into the electrical components, and as a result malfunctions and dangers could occur.

Clean and disinfect the bed before using it again. Also, at the same time, perform a visual inspection to check for any mechanical damages. You will find detailed information on this in the inspection list.

7 Guidance and manufacturer's declaration

Guidance and manufacturer's declaration

– Electromagnetic emission

The *medizinisches Bett* is intended for use in the electromagnetic environment specified below.

The customer or the user of the *medizinisches Bett* should assure that it is used in such an environment.

Emission test	Compliance	Electromagnetic environment - guidance
RF emissions CISPR 11 (partly)	Group 1	The medical used bed uses RF energy only for its internal function. Therefore, its RF emissions are very low and are not likely to cause any interference in nearby electronic equipment. The <i>medizinisches Bett</i> is suitable for use in all establishments other than domestic and those directly connected to the public-voltage power supply network that supplies buildings used for domestic purpose.
RF emissions CISPR 11 (partly)	Class B	
Harmonic emissions IEC 61000-3-2	Class A	
Voltage fluctuations/flicker emissions IEC 61000-3-3	Complies	

– Electromagnetic immunity

The *medizinisches Bett* is intended for use in the electromagnetic environment specified below.

The customer or the user of the *medizinisches Bett* should assure that it is used in such an environment.

Immunity test	IEC 60601 test level	Compliance level	Electromagnetic environment - guidance
Electrostatic discharge (ESD) IEC 61000-4-2	± 6 kV contact ± 8 kV air	± 6 kV contact ± 8 kV air	Floors should be wood, concrete or ceramic tile. If floors are covered with synthetic material, the relative humidity should be at least 30%.
Electrostatic transient/burst IEC 61000-4-4	± 2 kV for power supply lines ± 1 kV for input/output lines	± 2 kV for power supply lines ± 1 kV for input/output lines	Mains power quality should be that of a typical commercial or hospital environment.
Surge IEC 61000-4-5	± 1 kV differential mode ± 2 kV common mode	± 1 kV differential mode ± 2 kV common mode	Mains power quality should be that of a typical commercial or hospital environment.
Voltage dips, short interruptions and voltage variations on power supply input lines IEC 61000-4-11	< 5 % U_T (>95 % dip in U_T) for 0.5 cycle 40 % U_T (60 % dip in U_T) for 5 cycles 70 % U_T (30 % dip in U_T) for 25 cycles < 5 % U_T (>95 % dip in U_T) for 5 sec	< 5 % UT (>95 % dip in UT) for 0.5 cycle 40 % UT (60 % dip in UT) for 5 cycles 70 % UT (30 % dip in UT) for 25 cycles < 5 % UT (>95 % dip in UT) for 5 sec	Mains power quality should be that of a typical commercial or hospital environment. If the user of the <i>medizinisches Bett</i> requires continued operation during power mains interruptions, it is recommended that the <i>medizinisches Bett</i> be powered from an uninterruptible power supply or a battery.
Power frequency (50/60 Hz) magnetic field IEC 61000-4-8	3 A/m	3 A/m	Power frequency magnetic fields should be at levels characteristic of a typical location in a typical commercial or hospital environment.

Note: U_T is the a. c. mains voltage prior to application of the test level.

– Electromagnetic immunity

The *medizinisches Bett* is intended for use in the electromagnetic environment specified below.

The customer or the user of the *medizinisches Bett* should assure that it is used in such an environment.

Immunity test	IEC 60601 test level	Compliance level	Electromagnetic environment - guidance
Conducted RF IEC 61000-4-6 Radiated RF IEC 61000-4-3	3 V 150kHz-80MHz 3 V/m 80MHz-2500MHz	3 V 150kHz-80MHz 3 V/m 80MHz-2500MHz	<p>Portable and mobile RF communications equipment should be used no closer to any part of the EQUIPMENT <i>medizinisches Bett</i>, including cables, than the recommended separation distance calculated from the equation applicable to the frequency of the transmitter.</p> <p>Recommended separation distance:</p> $d = \left[\frac{3,5}{3} \right] \sqrt{P} \quad 150 \text{ kHz to } 80 \text{ MHz}$ $d = \left[\frac{3,5}{3} \right] \sqrt{P} \quad 80 \text{ MHz to } 800 \text{ MHz}$ $d = \left[\frac{2}{3} \right] \sqrt{P} \quad 800 \text{ MHz to } 2,5 \text{ GHz}$ <p>where p is the maximum output power rating of the transmitter in watts (W) according to the transmitter manufacturer and d is the recommended separation distance in metres (m).</p> <p>Field strengths from fixed RF transmitters, as determined by an electromagnetic site survey, should be less than the compliance level in each frequency range.</p> <p>Interference may occur in the vicinity of equipment marked with the following symbol:</p> 

NOTE 1 At 80 MHz and 800 MHz, the higher frequency range applies.

NOTE 2 These guidelines may not apply in all situations. Electromagnetic propagation is affected by absorption and reflection from structures, objects and people.

^a Field strengths from fixed transmitters, such as base stations for radio (cellular/cordless) telephones and land mobile radios, amateur radio, AM and FM radio broadcast and TV broadcast cannot be predicted theoretically with accuracy. To assess the electromagnetic environment due to fixed RF transmitters, an electromagnetic site survey should be considered. If the measured field strength in the location in which the *medizinisches Bett* is used exceeds the applicable RF compliance level above, the *medizinisches Bett* should be observed to verify normal operation. If abnormal performance is observed, additional measures may be necessary, such as reorienting or relocating the *medizinisches Bett*.

^b Over the frequency range 150 kHz to 80 MHz, field strengths should be less than 3 V/m.

Recommended separation distances between portable and mobile RF communications equipment and the *medizinisches Bett*

The *medizinisches Bett* is intended for use in an electromagnetic environment in which radiated RF disturbances are controlled.

The customer or the user of the *medizinisches Bett* can help prevent electromagnetic interference by maintaining a minimum distance between portable and mobile RF communications equipment (transmitters) and the *medizinisches Bett* as recommended below, according to the maximum output power of the communications equipment.

Rated maximum output of transmitter W	Separation distance according to frequency of transmitter m		
	150 kHz to 80 MHz $d = \left[\frac{3,5}{3} \right] \sqrt{P}$	80 MHz to 800 MHz $d = \left[\frac{3,5}{3} \right] \sqrt{P}$	800 MHz to 2,5 GHz $d = \left[\frac{2}{3} \right] \sqrt{P}$
0,01	0,12	0,12	0,23
0,1	0,37	0,37	0,74
1	1,17	1,17	2,33
10	3,69	3,69	7,38
100	11,67	11,67	23,33

For transmitters rated at a maximum output power not listed above the recommended separation distance d in metres (m) can be estimated using the equation applicable to the frequency of the transmitter, where P is the maximum output power rating of the transmitter in watts (W) according to the transmitter manufacturer.

NOTE 1 At 80 MHz and 800 MHz, the separation distance for the higher frequency range applies.

NOTE 2 These guidelines may not apply in all situations. Electromagnetic propagation is affected by absorption and reflection from structures, objects and people.

8 Regular inspections with service

Regular inspections facilitate the maintaining of the highest possible safety level, and are considered to be an important safety precaution. Medical devices must be inspected regularly in terms of safety according to the stipulated regulations of the manufacturer and the generally accepted rules of technology. The safety-related protection measures are subject to different requirements and demands. This also applies to the potential wear and tear in the daily use. To prevent such risks, constant and consistent compliance with the deadlines for regular functional testing is absolutely necessary. The manufacturer has no influence on the operator's adherence with respect to the observance of these regulations concerning electric beds. Bock facilitates the observance of the necessary precautionary measures to be taken by means of their time-saving services.

The execution of the inspection, assessment and documentation must be performed only by or under supervision of professional persons such as electricians or electro-technically instructed persons who have a thorough knowledge of the relevant provisions and are able to recognize possible impacts and hazards.

In the event that no person on the part of the user is eligible for the regular inspections or is commissioned, the Bock service offers you the assumption of the regular inspections with simultaneous control and observance of the corresponding intervals for a fee.

The company Hermann Bock GmbH specifies an inspection interval which stipulates that a safety-technical inspection is to be executed at least once annually, and with each re-use of the bed.

For support purposes, Hermann Bock GmbH will provide you with the inspection list in the assembly and operation manual for carrying out all the necessary tests. Please copy the checklist as a form for your inspection. The checklist serves as evidence report of the performed inspection and must be kept on file.

The inspection list can also be downloaded from the Internet: www.bock.net.

Attention: Unauthorised technical changes to the product voids all warranty claims.

Inspection list for Bock nursing care beds

Page 1 of 2

Issuing date: 09.10.2018

Model designation		
Serial / Inventory-No.:		
Year of manufacture:		
Manufacturer:	Hermann Bock GmbH	

Visual inspection:

No.	Description	Yes	No	Remark
General:				
1	Type plate/sticker present on bed and legible?	<input type="checkbox"/>	<input type="checkbox"/>	
2	Operating manual available?	<input type="checkbox"/>	<input type="checkbox"/>	
3	Is the safe working load as per type plate (patient weight + mattress weight + accessory weight) observed?	<input type="checkbox"/>	<input type="checkbox"/>	
4	Are the accessories (e.g. lifting pole incl. handle and belt, stand-up aid, wall deflector rollers, etc.) in perfect condition? Are all accessories securely fixed and without signs of wear? Is the handle on the lifting pole not older than 5 years (service life of the handle according to the manufacturer's specifications)?	<input type="checkbox"/>	<input type="checkbox"/>	
Electric components:				
5	Power cables, connecting cables and plugs without cable breaks, pressure and kinking points, abrasions, porous points and exposed wires?	<input type="checkbox"/>	<input type="checkbox"/>	
6	Strain relief firmly fastened and efficient?	<input type="checkbox"/>	<input type="checkbox"/>	
7	Correct and secure cable leading and cable connections?	<input type="checkbox"/>	<input type="checkbox"/>	
8	Housings of motors and hand control without damages?	<input type="checkbox"/>	<input type="checkbox"/>	
9	Motor lift pipes without damages?	<input type="checkbox"/>	<input type="checkbox"/>	
Chassis (with scissors construction beds) / end panels (of actuator beds):				
10	Chassis construction free of defects with no ruptured welding seams?	<input type="checkbox"/>	<input type="checkbox"/>	
11	Are the castors and bumper rollers (if available) without damages?	<input type="checkbox"/>	<input type="checkbox"/>	
12	Plastic end caps and mechanical connecting elements (screws, bolts, etc.) complete and without damages?	<input type="checkbox"/>	<input type="checkbox"/>	
Lying surface and end panels:				
13	Sprung wooden slats, aluminium/steel bars, carrier plate and/or springs without damages? (No cracks, no fractures, tight fit, enough pressure, etc.) <i>Only for nursing care bed dino:</i> Distance between aluminium bars less than 6 cm?	<input type="checkbox"/>	<input type="checkbox"/>	
14	Frame of lying surface and lifting parts free of defects with no ruptured welding seams?	<input type="checkbox"/>	<input type="checkbox"/>	
15	Plastic end caps and mechanical connecting elements (screws, bolts, etc.) complete and without damages?	<input type="checkbox"/>	<input type="checkbox"/>	
16	Tight fit and no cracks or breakages of head and foot end piece?	<input type="checkbox"/>	<input type="checkbox"/>	
Side rail:				
17	Are the side rails without cracks, breakages or damages?	<input type="checkbox"/>	<input type="checkbox"/>	
18	Is the distance between side guard rails is not more than 12 cm? <i>Only nursing care bed dino:</i> Distance between bars less than 6 cm? Distance between side rail and lying surface smaller than 6 cm?	<input type="checkbox"/>	<input type="checkbox"/>	
19	Is the height of the side rail above the mattress at least 22 cm? <i>Only nursing care bed dino:</i> Is the height of the side rail above the mattress at least 60 cm?	<input type="checkbox"/>	<input type="checkbox"/>	
20	<i>Only with split side rails:</i> Is the distance between the end part and side rails and/or distance between divided side rails less than 6 cm or greater than 31.8 cm?	<input type="checkbox"/>	<input type="checkbox"/>	

Inspection list for Bock nursing care beds		Page 2 of 2	Issuing date: 09.10.2018
Name / location:			
Address / Postcode / City:			
Station / Room:			
Name of examiner / Date:			

Functional testing:				
No.	Description	Yes	No	Remark
Side rail:				
21	Are the side rails running smoothly in the tracks and locking into place safely? <i>Only nursing care bed dino:</i> Smooth running of the doors on the aluminium profiles? Doors lock securely into the locking mechanism?	<input type="checkbox"/>	<input type="checkbox"/>	
22	Are the side guard rails/parts sufficiently mounted and firmly seated?	<input type="checkbox"/>	<input type="checkbox"/>	
23	Was the load stress test of the side rail without deformation?	<input type="checkbox"/>	<input type="checkbox"/>	
Lying surface:				
24	Back part, leg part adjustment and special functions properly and without any obstacles?	<input type="checkbox"/>	<input type="checkbox"/>	
25	Safe grid mechanism of lower leg rest (if available) in every step, even under stress?	<input type="checkbox"/>	<input type="checkbox"/>	
26	<i>Only domiflex 2 nursing care bed:</i> Is the clamping effect of the 6 eccentric clamps sufficient? If this is not the case, the stop nut must be tightened slightly!	<input type="checkbox"/>	<input type="checkbox"/>	
Chassis (with scissors construction beds) / end panels (of actuator beds):				
27	Hub adjustment properly and without any obstacles?	<input type="checkbox"/>	<input type="checkbox"/>	
28	Safe braking effect, blocking and free running of wheels?	<input type="checkbox"/>	<input type="checkbox"/>	
Electric components:				
29	Testing of hand control (keys and disabling function) all working properly without any defects?	<input type="checkbox"/>	<input type="checkbox"/>	
30	Battery/Bock battery/emergency lowering: Function properly and without any defects?	<input type="checkbox"/>	<input type="checkbox"/>	
General:				
31	Function of the accessories flawless and safe? (e.g. lifting pole incl. grab handle and belt, stand-up aids, wall deflector holder, etc.)	<input type="checkbox"/>	<input type="checkbox"/>	
Electric measuring:				
No.	Description	Yes	No	Remark
Insulation resistance - (must be only measured on old models before manufacture year of 2002.)				
32	Insulation resistance – measured value larger than 7 MΩ?	<input type="checkbox"/>	<input type="checkbox"/>	
Device leakage current - (This measurement does not have to be carried out for nursing care beds with a limoss drive set for nursing care beds manufactured from 2018-05 onwards, or for nursing care beds with a Dewert drive set for nursing care beds manufactured from 2015-07 onwards during the first 10 years of service life, if the visual and functional testing is passed, if this is a nursing care bed with a limoss or Dewert switched-mode power supply (SMPS). With these nursing care beds, the mains voltage is directly converted into a safety extra-low voltage of max. 35 V in the switch-mode power supply unit.)				
33	Device leakage current - measured value smaller than 0.1mA?	<input type="checkbox"/>	<input type="checkbox"/>	
Evaluation				
No.	Description	Yes	No	Remark
34	All values/inspection within the permissible range passed?	<input type="checkbox"/>	<input type="checkbox"/>	
In the event the inspection result did not pass:		<input type="checkbox"/> Repair <input type="checkbox"/> Singling out		
Date / Signature		Next inspection		



Hermann Bock GmbH
Nickelstr. 12
D-33415 Verl, Germany

Tel.: +49 52 46 92 05 - 0
Fax: +49 52 46 92 05 - 25
Internet: www.bock.net
E-Mail: info@bock.net

Our SALES PARTNERS

Our business partners pursue the same strategy as we do: quality, innovation and above-average standards that are internationally recognized. You can rely on our business partners as you can rely on us.

Please note that only our authorised personnel and our sales partners can provide training, supply of spare parts, repairs, inspections and other service. Otherwise, all warranty claims will be void.

A listing of our current distributors can be found under www.bock.net/contact/distribution-partners